

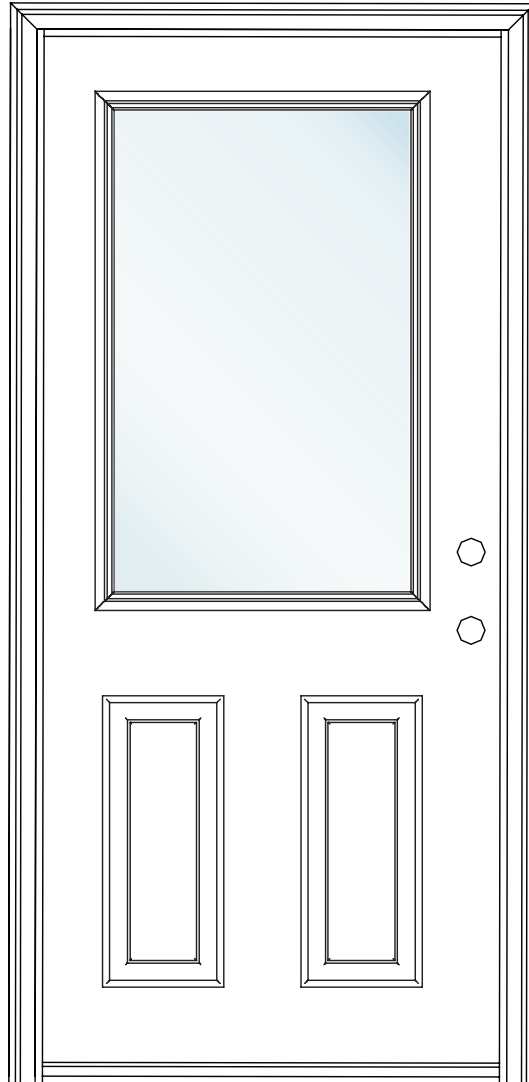

# INSTALLATION INSTRUCTIONS

## **FUSIONFRAME™ SINGLE**

### ENTRY DOOR



*\* Find QR Codes inside for additional information, helpful installation tips, and videos.*



Contact the local recycling waste management center for waste disposal in the area. Always check local waste requirements and carefully dispose of waste in accordance with Federal and other regulations.



Homes built before 1978 may contain lead paint. All replacement installations must comply with the U.S. EPA's Lead-Based Paint Renovation, Repair, and Painting Program (RRP Rule). Read more about the RRP Rule and lead-safe work practices, on the U.S. EPA's website at: [www.epa.gov/lead](http://www.epa.gov/lead)



# GETTING STARTED

## TOOLS & MATERIALS YOU WILL NEED

- Measuring Tape
- Pencil
- Utility Knife
- Reciprocating Saw
- Carpenter's Square
- Hammer or Mallet
- Level
- Shims
- Drill & Drill Bits
- Stiff Putty Knife
- (1) box 2½" - 3" Exterior Decking Screws
- (1) box 2½" Smooth Shank Screws
- High Quality Silicone Caulking in accordance with ASTM C 920, Class 25 & Caulking Gun
- AAMA approved Low-Expanding Window Insulation Foam in accordance with ASTM C, 1620
- Siding Removal Tool (Recommended) 
- Masking tape (Optional for Flat Brickmold)
- Table Saw (Optional for Flat Brickmold)



**REMEMBER: ALWAYS USE THE APPROPRIATE PERSONAL PROTECTIVE EQUIPMENT.**



Read these instructions carefully before starting installation. Product warranty does not cover damages resulting from improper installation.

## IMPORTANT NOTES BEFORE YOU BEGIN

- Inspect your package for any visible damages to the product. In addition, double check your paperwork with label on product(s) and verify all information is a match. Open packaging to confirm style, color and that order was shipped complete. Double check size of new unit by comparing it for fit to opening.
- If damages or irregularities are found, please scan the product's packaging QR Code label using your QR Code Scanner App to access ProVia's **After Sale Product Support** to enter a request for assistance or call Customer Service at 1-800-669-4711. Please be sure to provide order # and document with photos and/or videos.
- If you have ordered optional items, verify that they are included in packaging contents. This includes checking for multiple packages (For example, 1 of 2 and 2 of 2).
- For the entry door measuring guide and video, please tap or scan the QR codes shown.

GUIDE



VIDEO



- For FusionFrame™ installation tips video, tap or scan the QR code shown.

# A. PREPARE FUSIONFRAME™ ENTRY DOOR

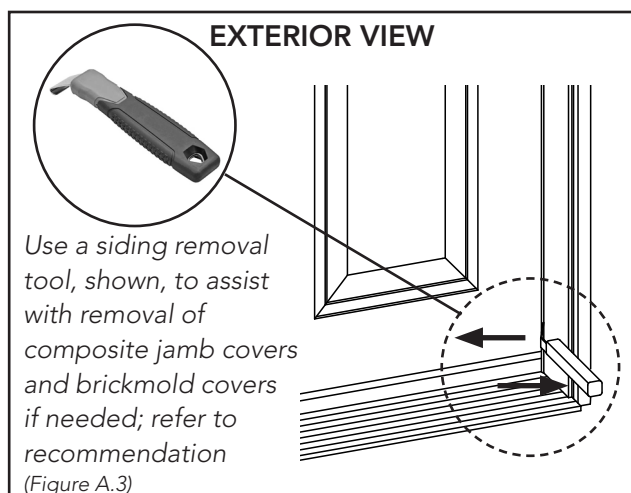
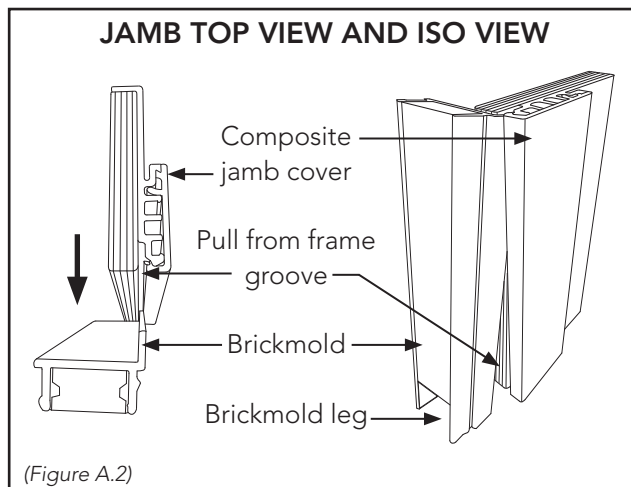
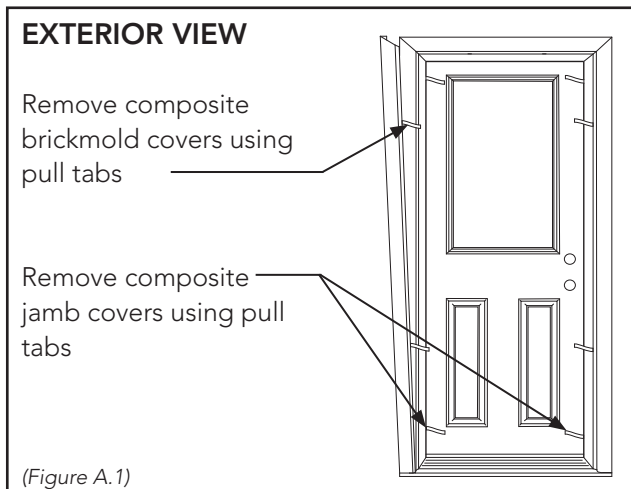

**FusionFrame brickmold covers and jamb covers are designed to be removed before installation. DO NOT re-install until indicated within this instruction.**

1

Remove the side and header composite brickmold covers using the factory installed pull tabs or by following the recommendation given below. Carefully set aside to prevent damage. (Figure A.1)

2

Remove the side and header brickmold pieces. Begin at threshold, pulling brickmold leg away from the frame groove. Carefully set aside to prevent damage. (Figure A.2)

3

Remove side composite jamb covers by using the factory installed pull tabs or by following the recommendation given below. Carefully set aside to prevent damage. **The header composite jamb cover is NOT removable.** (Figure A.1 & A.2)

4

For units with a transom, remove each transom vertical jamb cover in addition to door unit jamb covers instructed in Step 3. **The transom sill cover is NOT removable.**



**ProVia® Recommended!** Use a siding removal tool to assist with the removal of composite jamb covers or brickmold covers. Place tool at bottom corner of jamb cover, push tool into weathershipping to grab back edge and tap back end of tool to pop cover. For brickmold cover removal, align tool with joint of cover, tap tool into joint and pull straight away from brickmold. (Figure A.3)

5

Remove shipping slats from the bottom of threshold.

## B. INSTALL PREPARATION

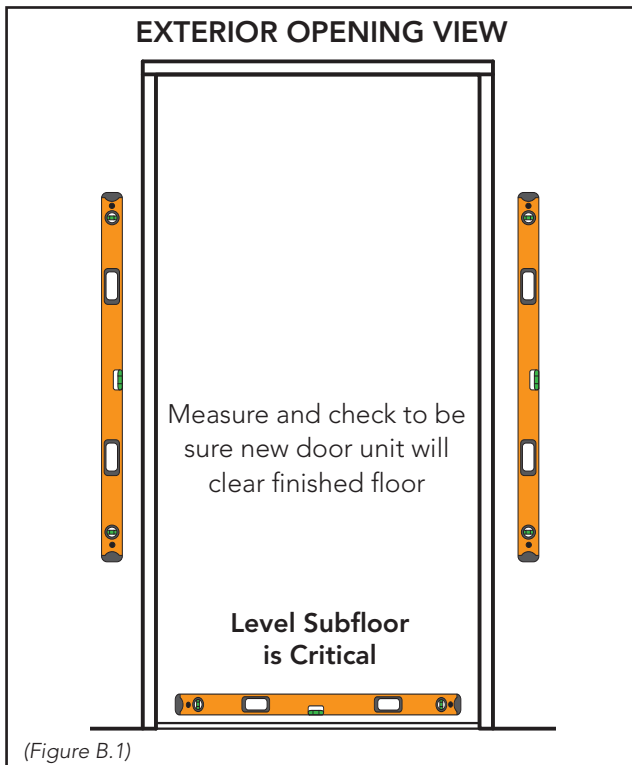

1

Opening preparation for replacement applications, remove existing door slab and jamb to expose rough opening.

**NOTE:** The rough opening will be from jack stud to jack stud, and sub-floor to underside of header. (Figure B.1)

2

Clean rough opening of all dirt, debris, and obstructions.

3

Check for level subfloor. Measure and check to be sure new door unit will clear carpet, hardwood, rug, etc. Subfloor may need to be built up for clearance.

4

Check to see if opposing walls are on the same plane. If not, new door unit will need to be adjusted to plane during installation.



**IMPORTANT!** Be sure shipping slats have been removed from bottom of threshold before dry fit.

5

Dry fit unit to confirm opening clearances, dust cup clearance (if applicable), plane of door, and support of exterior edge of threshold.

6

Remove door unit from opening and make any necessary modifications to the opening.

7

Install flashing/pan system to sill area in accordance with local building codes and best practices. Replace drip cap if necessary. (Figure B.2)



## B. INSTALL PREPARATION (CONTINUED)

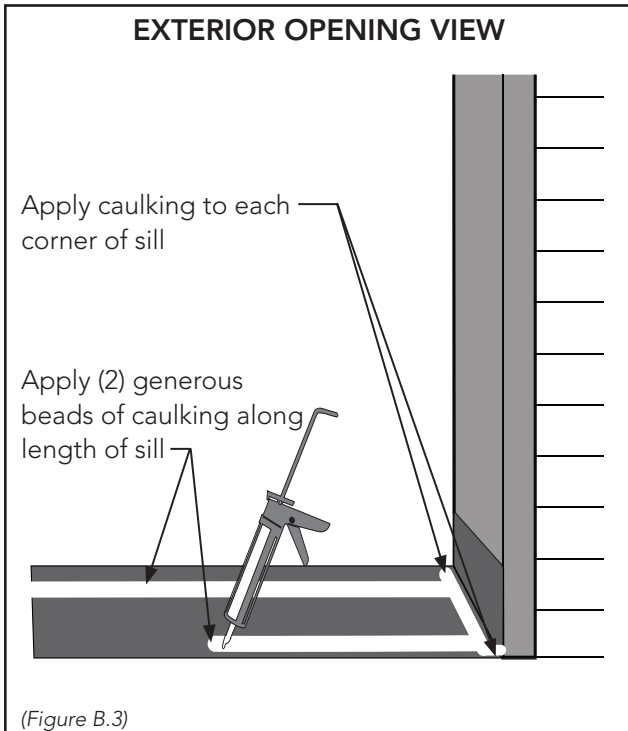

8

If exterior edge of threshold requires support, add material to the exterior surface of the structure at the sill.

9

Apply (2) generous beads of premium caulking compound in a STRAIGHT LINE, on top of flashing and along entire length of rough opening sill. Place first bead of caulking to the exterior leading edge of sill. The second bead of caulking should be placed along a composite edge of the threshold, towards interior. Apply caulking in each corner of sill. (Figure B.3)

## C. INSTALL NEW DOOR UNIT

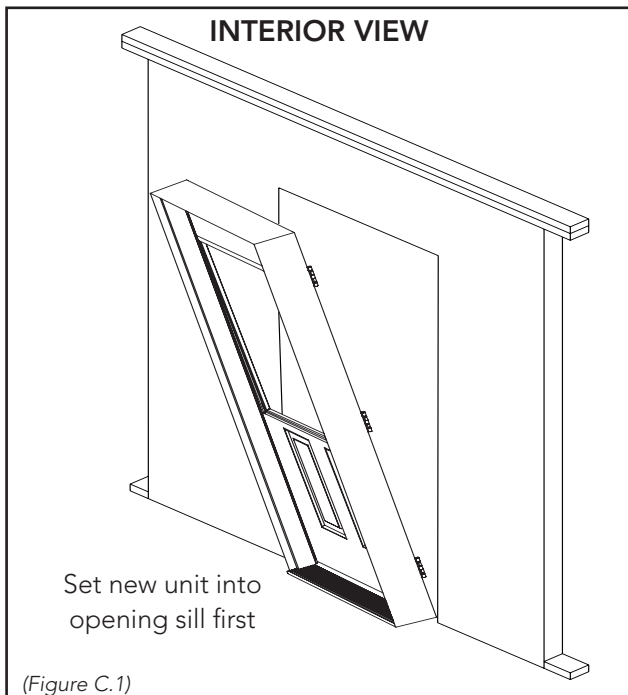

1

Set new door unit into opening sill first, as shown in illustration. (Figure C.1)

2

From the interior side, center door on existing base board or paint lines.



**IMPORTANT!** This unit is installed without brickmold attached, therefore utilizing cleats on interior wall or exterior jamb face may assist. Be sure door jamb does NOT protrude past exterior sheathing to avoid compromising FusionFrame™ brickmold installation.

## C. INSTALL NEW DOOR UNIT (CONTINUED)

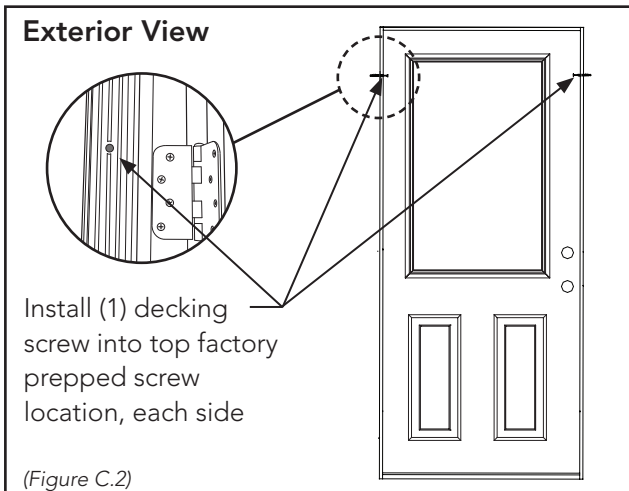

3

Check and note plane of door in rough opening. **Door plane needs to be continuously monitored throughout the installation.** Refer to Section C, Step 8 and Figure C.5 for more information.



**IMPORTANT!** *Plane adjustment is critical for door operation and sealing performance. Confirm all adjustments made do not compromise plane. Adjustments to plane after complete install may require removal and re-installation.*

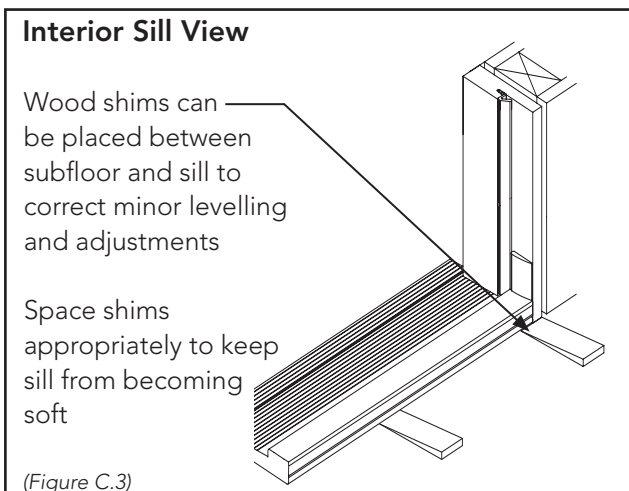

4

Install (1) decking screw into the top factory prepped screw location, each exterior jamb side. **DO NOT** over tighten screws. (Figure C.2)

5

Check for level sill. If necessary, place wood shims between subfloor and jamb to correct minor leveling and margin adjustments,  $\frac{1}{8}$ " or less. (Figure C.3)

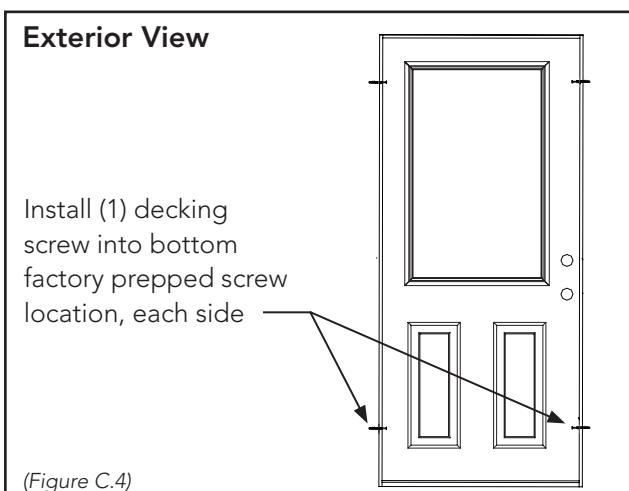

**IMPORTANT!** *A level sill is critical. If sill is not flat, straight and level, it must be shimmed for proper operation of door. Be careful to NOT over shim. Improper shimming may change the margins and jeopardizing operational performance of door.*

6

Install (1) decking screw into the bottom factory prepped screw location, each exterior jamb side. **DO NOT** over tighten screws. (Figure C.4)

## C. INSTALL NEW DOOR UNIT (CONTINUED)

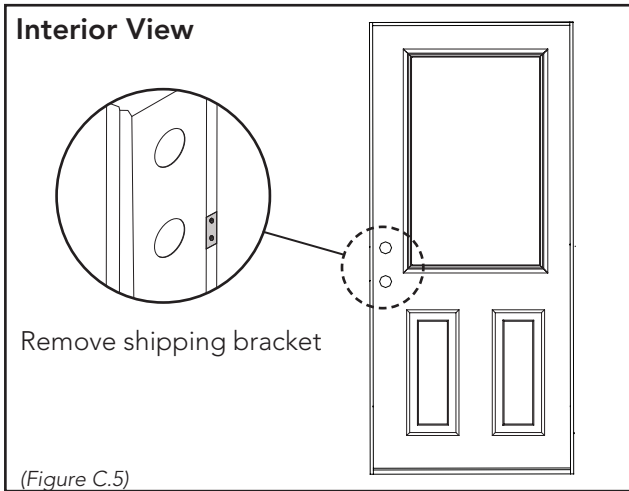

**IMPORTANT!** Be careful with initial opening of door slab. Shipping brackets **WILL DAMAGE JAMB** if door slab is opened without lifting to unweight it.

7

Remove jamb screws from shipping bracket. Before opening the door, use handle set prepped holes to lift door slab to unweight and then open. Remove bracket and discard. (Figure C.5)

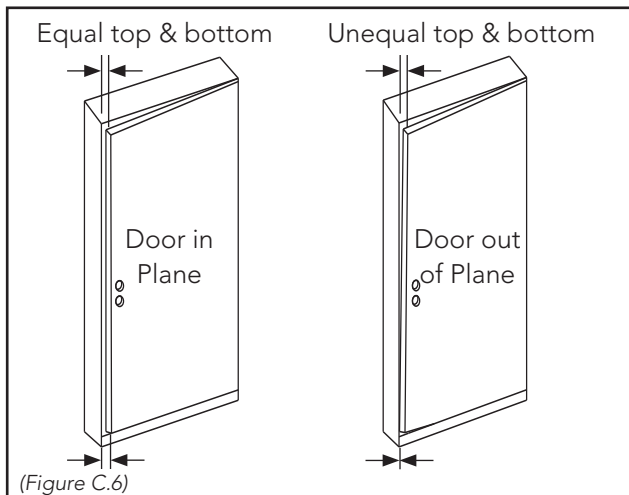

8

Inspect plane of door by comparing edge of door slab to edge of strike jamb. The edges should be parallel. If door is out of plane (the slab and jamb edge are not parallel), refer to troubleshooting table and adjust accordingly. (Figure C.6)



**IMPORTANT!** Pre-drill for all hinge and interior shim screws to be installed using a  $\frac{1}{8}$ " drill bit.

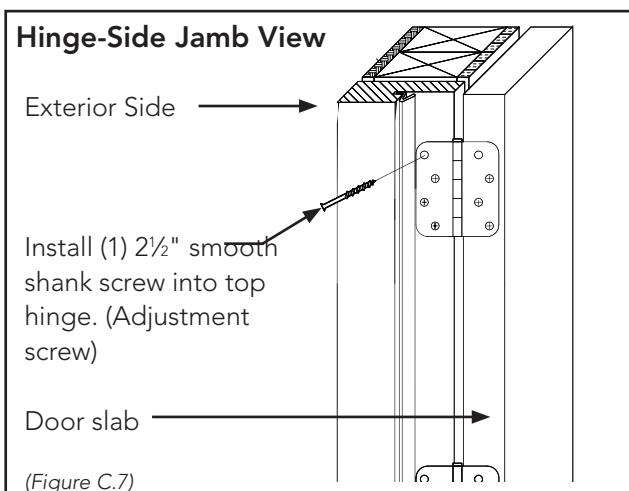

9

Install (1) 2½" smooth shank screw (not provided) into top hinge to draw the top of the door slab towards the hinge side jamb. Use screw for adjustments. (Figure C.7)



**IMPORTANT!** Do not allow initial setting screws, installed in Steps C4 and C6, to interfere with future adjustments required during remaining installation.

## C. INSTALL NEW DOOR UNIT (CONTINUED)

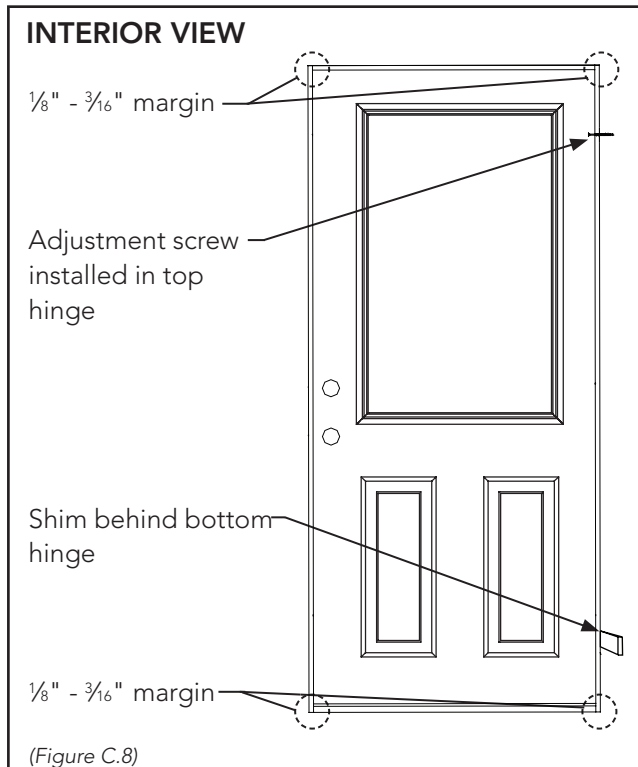

10

To counteract the weight of the door slab compressing against the bottom hinge and jamb, add shims behind the bottom hinge location. Use the adjustment screw in top hinge and the shim behind bottom hinge to set a 1/8" - 3/16" margin between door slab and jamb at all (4) corners. (Figure C.8)



**IMPORTANT! Proper shimming application; stack wedge shaped shims contrasting and plane to plane.**

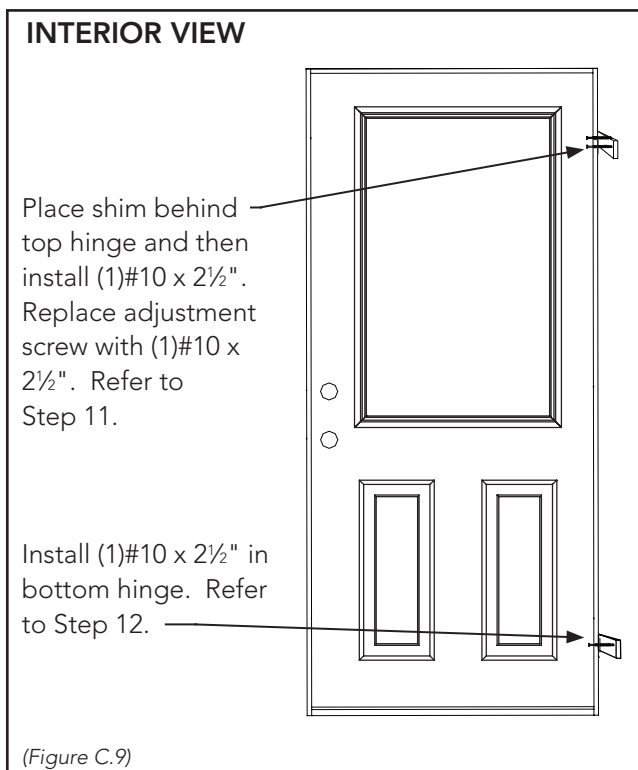

11

After all margins are set, shim behind the top hinge until tight to the adjuster screw. Install (1) #10 x 2 1/2" screw (provided) in the remaining hole location of hinge. Then replace the adjustment screw with (1) #10 x 2 1/2" screw. (Figure C.9)

**NOTE:** The #10 x 2 1/2" hinge screws will be included in the hardware box or stapled to the side of the jamb.

- For a **3-HINGE DOOR**, (4) screws will be provided.
- For a **4-HINGE DOOR**, (5) screws will be provided

12

Install (1) #10 x 2 1/2" screw in the bottom hinge. Check all corner margins. If margins have deviated, adjust shims accordingly. Refer to Troubleshooting Section. (Figure C.9)



## C. INSTALL NEW DOOR UNIT (CONTINUED)

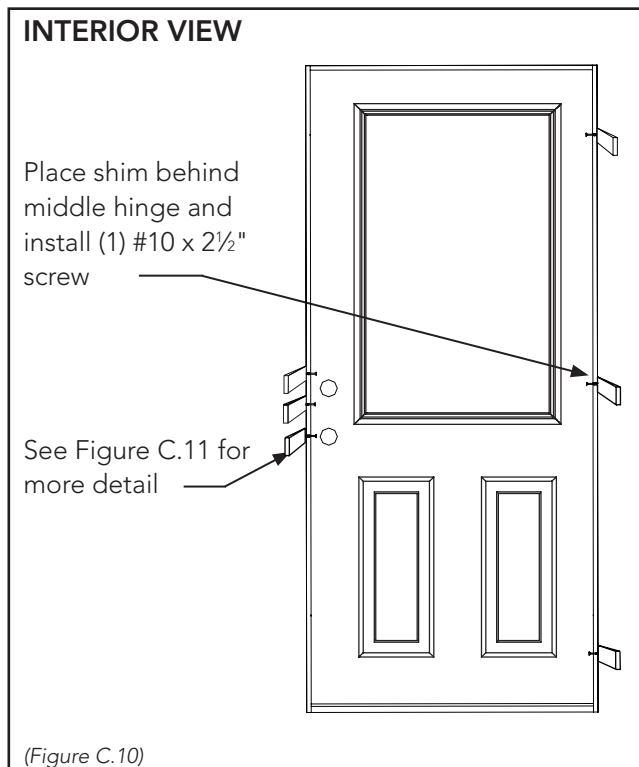

13

Shim behind the middle hinge and install (1) #10 x 2½" screw in the open hole. For a 4-HINGE DOOR, repeat for each middle hinge. (Figure C.10)



**IMPORTANT!** Be careful to **NOT** over shim. Improper shimming may change the margins and jeopardize the operational performance of door.



**IMPORTANT!** Pre-drill for all screws to be installed using a ⅛" drill bit to protect frame from splitting.

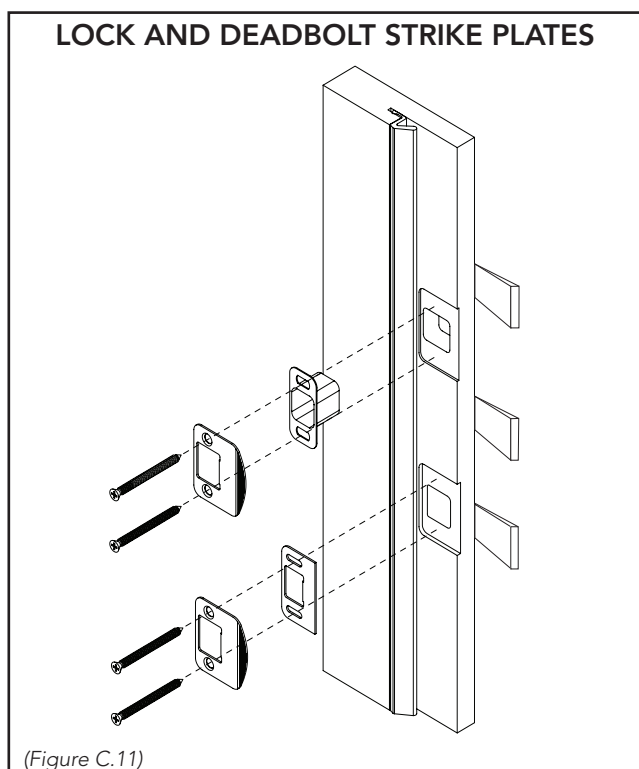

14

Shim directly above and below the dead bolt prep location as well as directly behind lock set prep. Be sure to maintain ⅛" - ⅜" margins. (Figure C.11)

15

Install (2) #8 x 2½" screws to secure the deadbolt strike plate and (2) #8 x 2½" screws to secure the lock set strike plate. (Figure C.11)

**NOTE:** (4) #8 x 2½" hardware installation screws will be included in the hardware box or stapled to the side of the jamb.

## C. INSTALL NEW DOOR UNIT (CONTINUED)

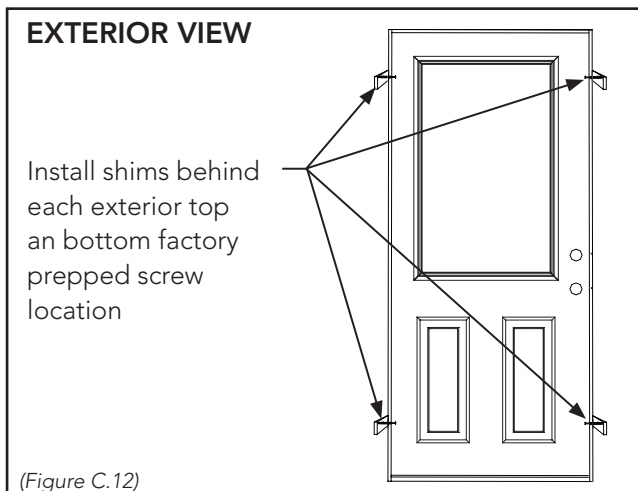

16

On exterior side of door, install shims at each top and bottom factory prepped screw location. (Figure C.12)

17

Shim and install (1) decking screw into the middle factory prepped screw location, each exterior jamb side. (Figure C.13)



**IMPORTANT!** If exterior shims are aligned with hinge locations, additional interior hinge shims may not be required.

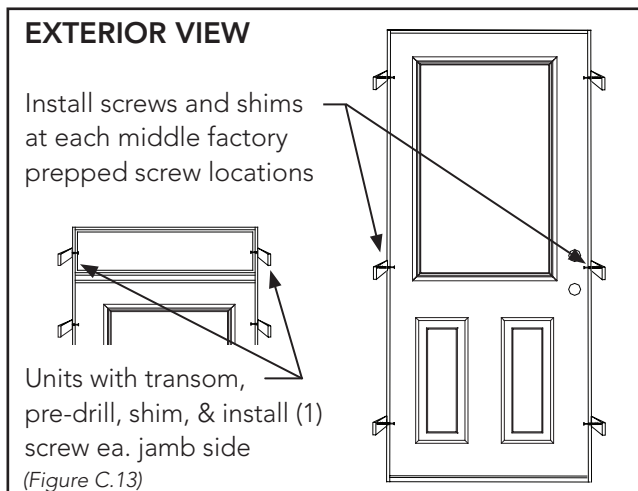

18

ONLY for units WITH a transom, center (1) shim on each transom vertical jamb. Pre-drill and install a 2½" decking screw at each transom shim location. Shim at least (1) interior location on transom header, do not secure with screw. (Figure C.14)

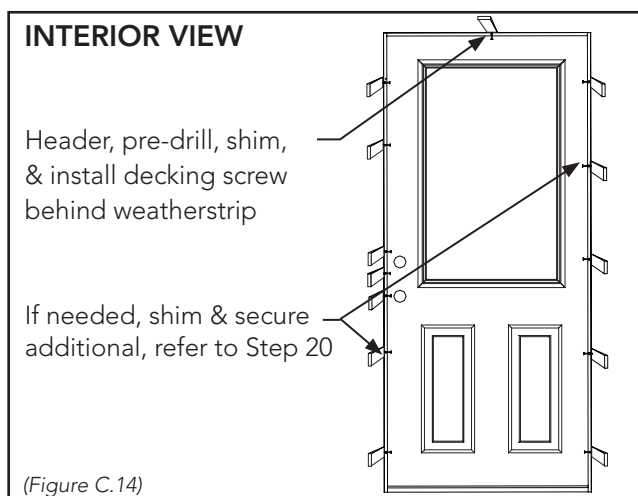

19

ONLY for units WITHOUT a transom, shim at least (1) interior location on the header. Pull back weatherstripping, pre-drill and install a 2½" decking screw at the shim location. (Figure C.14)

20

Final check on all margins. Adjust shims and screws as needed to achieve and maintain a ⅛" - ⅜" margin around the entire door. Refer to Troubleshooting Section.

**NOTE:** Shim and secure additional areas of interior jamb as needed to achieve and maintain required margins. (Figure C.14)

## D. INSTALL FUSIONFRAME™ JAMB COVERS & BRICKMOLD

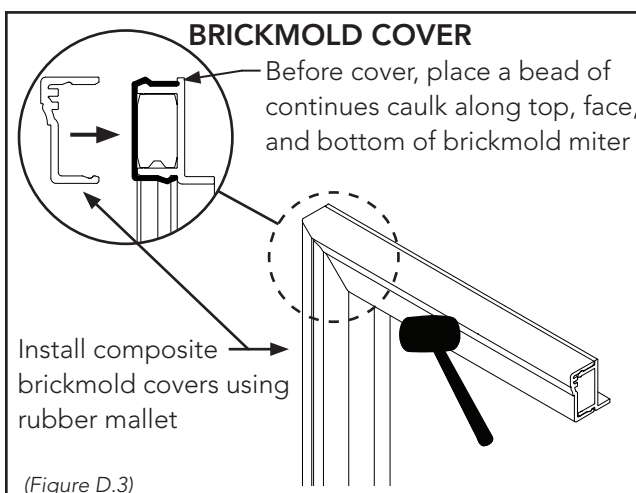
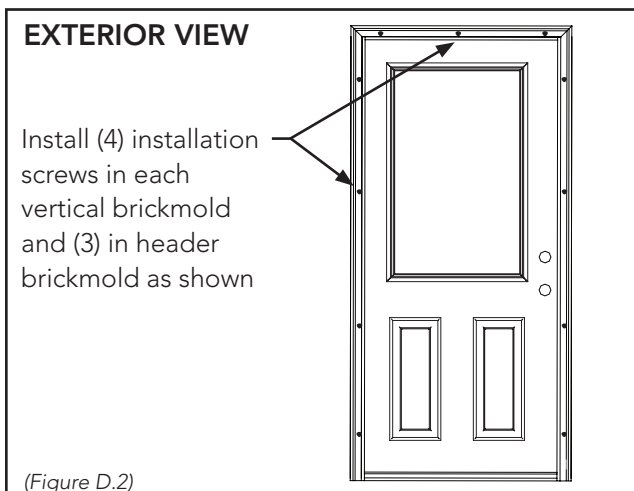
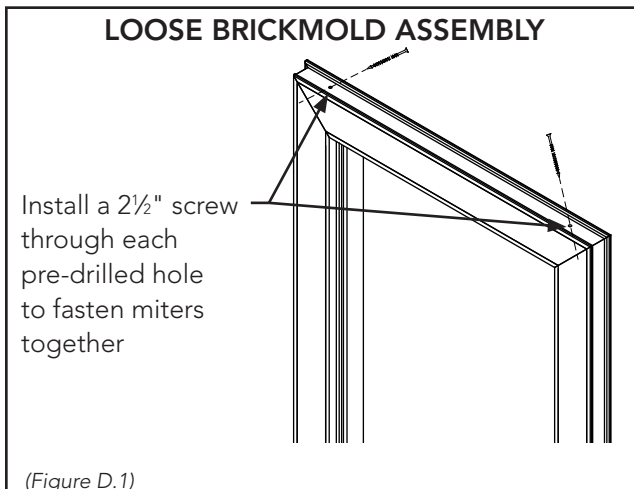

1

Install composite jamb covers. Use a rubber mallet or heel of hand to firmly set.

2

Be sure all composite brickmold covers have been removed from loose brickmold.

3

Units ordered with 3½" flat trimmable brickmold covers can be field trimmed with a circular saw. Measure from the brickmold groove to the exterior veneer. Place masking tape on the finished face before cutting to protect the finished surface. *Note, cutting the flat trim will likely leave an unfinished edge exposed, unless trim is installed in a brick veneer opening.*

4

Before installation, place loose brickmold header and each side leg on a level surface. Install a 2½" screw through each pre-drilled hole to fasten miters together. This will keep miter tight after composite cover is re-installed. **Securing miters with screws prevents miters from opening after installation. Gaps in composite cover miters will result if not fastened.** (Figure D.1)

5

Apply a bead of caulking to each vertical and header face of exterior sheathing to seal brickmold to sheathing. Tie each vertical bead of caulk to sill caulking to create a continuous seal.

6

Align insertion leg of brickmold with groove of jamb. Carefully, tap each vertical and header brickmold into place until fully seated.

7

Install (4) installation screws in each vertical brickmold and (3-4) in header brickmold to secure. **DO NOT roll brickmold miters when installing screws.** (Figure D.2)

8

Before installing composite brickmold covers, place a bead of continuous caulk along top, face, and bottom of brickmold miter, each side and as shown (Figure. D.3)

9

Install composite brickmold covers. Use a rubber mallet or heel of hand to firmly set in place. Immediately remove any excess caulking from miter areas. (Figure. D.3)

# E. INSULATE AND SEAL

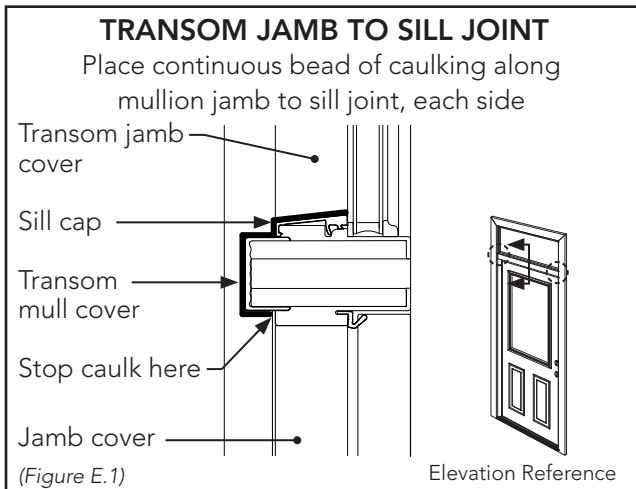

**1** Insulate by using an AAMA approved ASTM C 1620 Low-Expanding Foam to fill cavities between frame and opening.



**IMPORTANT!** Over use of Low-Expanding Foam or use of any non Low-Expanding Foam may cause frame to bow, jeopardizing operational performance of door.

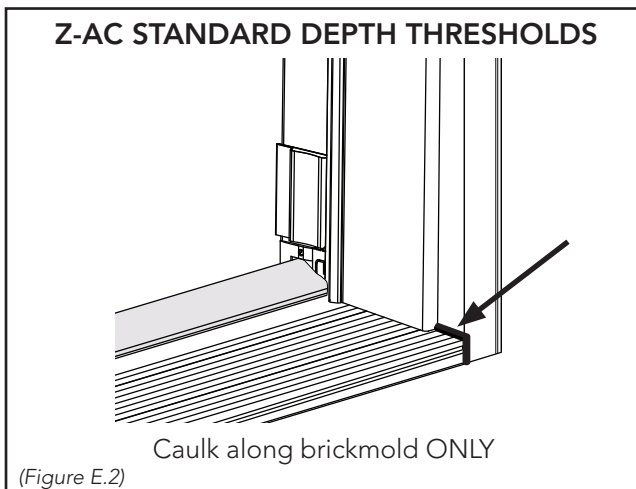

**2** For units with a transom, place a bead of continuous caulking at the transom mullion jamb cover to sill joint; along top, front face, and underside of cover, each jamb side and as shown. (Figure E.1)

**3** Caulk threshold:

- **Z-AC™** thresholds with a  $4\frac{1}{16}$ " or  $6\frac{1}{16}$ " jamb depth, only need caulked at the brickmold and threshold intersection. If desired, caulk along entire joint where jamb meets the threshold. (Figure E.2)

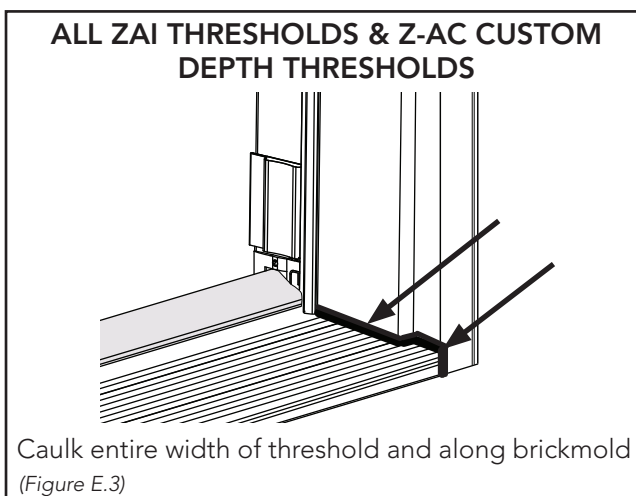

- **Z-AC** threshold with custom jamb depth: caulk along entire joint of threshold where the jamb meets the threshold and along the brickmold joint. (Figure E.3)
- **ZAI** threshold: caulk along entire joint where jamb meets the threshold and along the brickmold joint. (Figure E.3)

## F. THRESHOLD: Z-AC™ (AUTO-ADJUSTING) THRESHOLD ONLY

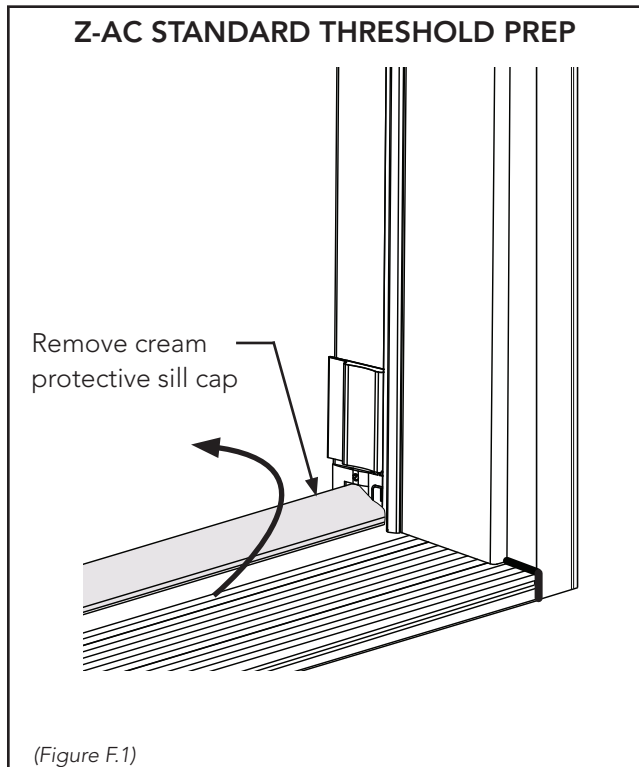

- 1 Remove the cream colored protective sill cap cover. For inswing door units, grasp cover from the exterior side, lift and pull. The cream cover may break, this is typical. (Figure F.1)

**NOTE:** If Z-AC sill cap is not allowing door slab to close or function properly, refer to Troubleshooting Section.

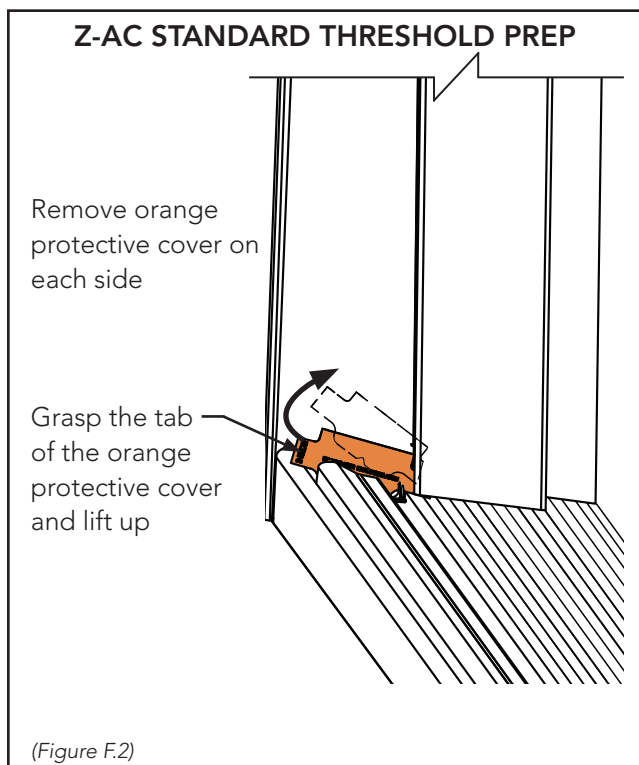

- 2 Remove the orange protective covers located at each jamb. Grasp the tab of the orange protective cover, marked "Pull-Up". Lift up and away from the sill base (pliers may be required). (Figure F.2)

**NOTE:** A small portion of the gasket, at the outside edge **ONLY**, will be removed with the protective cover, this is typical. **DO NOT** remove any portion of foam gasket in removal of orange tab.

For ZAI threshold instructions, refer to section G, page 13

## G. THRESHOLD: ZAI (ADJUSTABLE) THRESHOLD ONLY

The ZAI (Adjustable) threshold allows for adjustment of the sill height, thus providing a consistent and even seal. To adjust sill cap height, follow one of the two methods shown below:

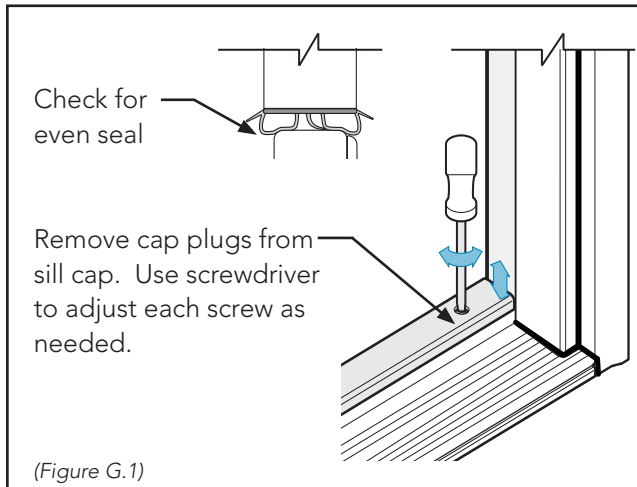

OR

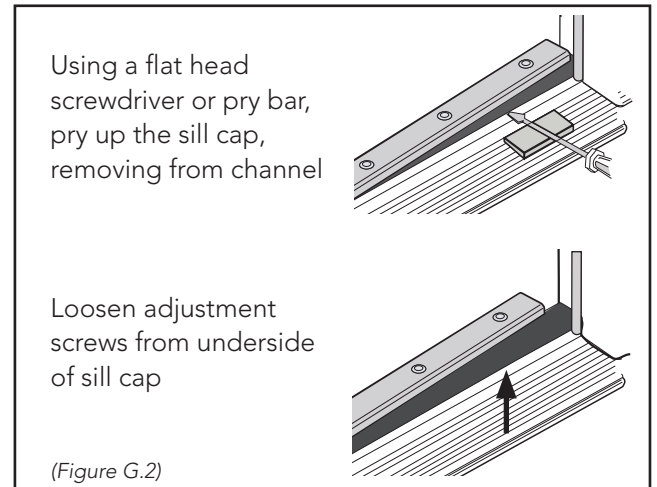

### REMOVE CAP PLUGS:

- 1 Place tape around the cap plug to protect the finish. Use a flat blade to pry the cap plugs away from cap.
- 2 Use a screwdriver to adjust each screw as needed to achieve necessary height. (Figure G.1)
- 3 Open and close door to check adjustments.
- 4 Check for an even seal along full length of door sweep. Repeat process until proper seal is achieved. (Figure G.1)
- 5 Re-install the cap plugs. Use a rubber mallet if needed to secure plugs in place. If cap plugs are damaged during adjustment, replace with new plugs.

### REMOVE SILL CAP:

- 1 Place a small piece of wood blocking on sill deck to prevent damage. At one end of the sill, use a flat head screwdriver or pry bar to pry the cap upward and away from the sill channel. Continue to work along the full length of threshold until fully removed from channel. (Figure G.2)
- 2 Access adjustment screws from the underside of the sill cap. Using a screwdriver, adjust screws as needed to achieve necessary height. (Figure G.2)
- 3 Re-install sill cap by snapping into channel. If needed, use a rubber mallet to tap into place. Leg of the sill cap should touch the threshold deck when properly seated.
- 4 Open and close door to check adjustments.
- 5 Check for an even seal along full length of door sweep. Repeat above steps until proper seal is achieved.



# TROUBLESHOOTING & TIPS

Problem	Cause	SOLUTION
Door slab is not sealing against weatherstrip and/or strike-side, top of door slab protrudes past frame.	Door slab is out of plane with frame.	<ol style="list-style-type: none"> <li>1. Shift strike-side, bottom corner of frame towards exterior.</li> <li>2. Shift hinge-side, top corner of frame towards exterior.</li> </ol>
Door slab is not sealing against weatherstrip and/or strike side, bottom of door slab protrudes past frame.	Door slab is out of plane with frame.	<ol style="list-style-type: none"> <li>1. Shift strike-side, top corner of frame towards exterior.</li> <li>2. Shift hinge-side, bottom corner of frame towards exterior.</li> </ol> <p><i>*Tip: If ordered with brickmold attached, using full-thread screws will allow the frame to be 'held' out from exterior sheathing in order to adjust plane.</i></p>
Strike-side margin is too small. Door slab hits frame on strike-side.	Over-shimmed.	<ol style="list-style-type: none"> <li>1. Slightly loosen hinge-side shims and pull hinge-side frame towards stud by tightening hinge screws.</li> <li>2. Loosen strike-side shims and pull strike-side frame towards stud by tightening screws behind weatherstripping.</li> <li>3. Reduce shims from middle hinge (middle hinge over-shimmed).</li> </ol>
Strike-side margin is too large, more than $\frac{3}{16}$ ".	Under-shimmed.	<ol style="list-style-type: none"> <li>1. Increase shim depth behind jamb on hinge-side.</li> <li>2. Increase shim depth behind jamb on strike-side.</li> </ol>
Tapered header margin. Margin is larger on strike-side.	<ol style="list-style-type: none"> <li>1. Not properly shimmed behind hinges.</li> <li>2. Sill is not level</li> </ol>	<ol style="list-style-type: none"> <li>1. Adjust shims behind top and bottom hinges to correct tension and/or compression.</li> <li>2. Shim directly under jamb on the hinge-side to raise door slab within the frame, <math>\frac{1}{8}</math>" max.</li> </ol>
Tapered header margin. Margin is smaller on strike-side.	<ol style="list-style-type: none"> <li>1. Not properly shimmed behind hinges.</li> <li>2. Sill is not level</li> </ol>	<ol style="list-style-type: none"> <li>1. Adjust shims behind top and bottom hinges to correct tension and/or compression.</li> <li>2. Shim directly under jamb on the strike-side to raise the jamb to create proper margin, <math>\frac{1}{8}</math>" max.</li> </ol>
Tapered margin above top hinge. Margin is larger at the hinge.	Under shimmed at middle and top hinge.	Increase shims behind top and/or middle hinge.
Tapered margin above top hinge. Margin is smaller at the hinge.	Over shimmed at middle or top hinge.	Decrease shims behind top and/or middle hinge.
Tapered margin below bottom hinge. Margin is larger at the hinge.	Under shimmed at middle and bottom hinge.	Increase shims behind bottom and/or middle hinge.
Tapered margin below bottom hinge. Margin is smaller at the hinge.	Over shimmed at middle or bottom hinge.	Decrease shims behind bottom and/or middle hinge.
Middle strike-side margin is too small or too large above or below latch area.	Wood frame is bowed.	Secure additional shims behind weatherstripping at affected area.

*Troubleshooting & Tips continues on next page.*



## TROUBLESHOOTING & TIPS (CONT.)

Problem	Cause	SOLUTION
Door slab is not sealing tight against weatherstrip. (Door is in plane)	Adjustable strike plate has moved.	Remove strike plate cover. Shift adjustable strike plate to proper position and secure in place with (2) small brad nails. Reinstall strike plate cover.
Door knob is loose.	Screws have loosened from use.	1. Thread locker. 2. Install a small lock washer behind each screw.
Bottom door sweep is dragging.	1. Top margin is larger on strike-side. (See Solution 1 & 2) 2. Bow (upward) in sill/threshold. (See Solution 3)	1. Tighten top hinge screw to pull door slab up and towards frame. 2. If margin is ¼" or greater, door unit needs reset. Shim under sill and reset door. 3. Remove sill cap from threshold. Install screws through sill cap channel to pull threshold and sill downward. If this does not correct bow in threshold, removal of subfloor material will be required to level, then reset door.
Bottom door sweep is not sealing.	1. ZAI sill cap is too low. 2. Top margin is smaller on the strike-side. 3. Bow (downward) in sill/threshold.	1. Raise adjustable sill cap as needed. See page 9. 2. Top hinge is over shimmed. Adjust shims as needed. 3. Door unit needs reset. Shim under sill as needed to raise bow. Reset door.
Interference of Z-AC cap with door slab.	Sill cap may not be fully seated.	Snap front leg of sill cap into place. Leg of the sill cap should touch the threshold deck when properly seated. If needed, use a rubber mallet to tap into place.

***\*Please call Customer Service for additional installation inquiries at 1-800-669-4711.***

***\*For additional information and helpful videos, visit our Homepage for Installers by TAPPING or SCANNING the QR code shown.***

