

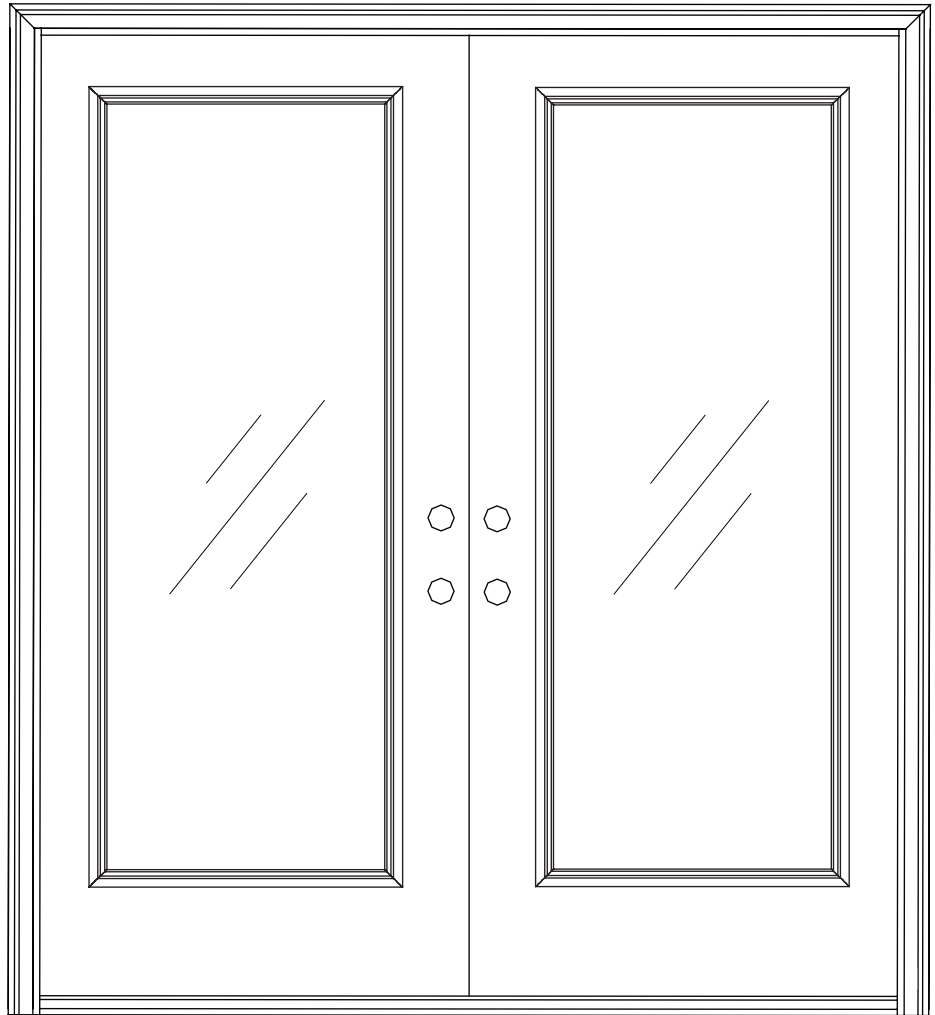

INSTALLATION INSTRUCTIONS

PERMATECH™ DOUBLE

ENTRY DOOR (FRENCH)



** Find QR Codes inside for additional information,
helpful installation tips, and videos.*



Contact the local recycling waste management center for waste disposal in the area. Always check local waste requirements and carefully dispose of waste in accordance with Federal and other regulations.



Homes built before 1978 may contain lead paint. All replacement installations must comply with the U.S. EPA's Lead-Based Paint Renovation, Repair, and Painting Program (RRP Rule). Read more about the RRP Rule and lead-safe work practices, on the U.S. EPA's website at: www.epa.gov/lead



GETTING STARTED

TOOLS & MATERIALS YOU WILL NEED

- Measuring Tape
- Pencil
- Utility Knife
- Reciprocating Saw
- Carpenter's Square
- Hammer or Mallet
- Level
- Shims
- Drill & Drill Bits
- Stiff Putty Knife
- (1) box 2½" - 3" Exterior Decking Screws
- (1) box 2½" Smooth Shank Screws
- High Quality Silicone Caulking in accordance with ASTM C 920, Class 25 & Caulking Gun.
- AAMA approved Low-Expanding Window Insulation Foam in accordance with ASTM C, 1620.



REMEMBER: ALWAYS USE THE APPROPRIATE PERSONAL PROTECTIVE EQUIPMENT.



Read these instructions carefully before starting installation. Product warranty does not cover damages resulting from improper installation.



PermaTech™ Composite Frame System: Available in white from our factory and can be field painted. Please see Section H of this manual for painting recommendations.

Important! DO NOT install a storm door onto the brickmold/jamb area of the composite frame, doing so will void the product warranty.



INSTALLER: Demonstrate function of double (French) door astragal to Homeowner. Be sure top and bottom astragal pins are correctly seated in designated locations to ensure proper function of unit.

IMPORTANT NOTES BEFORE YOU BEGIN

- Inspect your package for any visible damages to the product. In addition, double check your paperwork with label on product(s) and verify all information is a match. Open packaging to confirm style, color and that order was shipped complete. Double check size of new unit by comparing it for fit to opening.
- If damages or irregularities are found, please scan the product's packaging QR Code label using your QR Code Scanner App to access ProVia's **After Sale Product Support** to enter a request for assistance or call Customer Service at 1-800-669-4711. Please be sure to provide order # and document with photos and/or videos.
- If you have ordered optional items, verify that they are included in packaging contents. This includes checking for multiple packages (For example, 1 of 2 and 2 of 2).
- For the entry door measuring guide and video, please tap or scan the QR codes shown.

GUIDE



VIDEO



A. PREPARATION

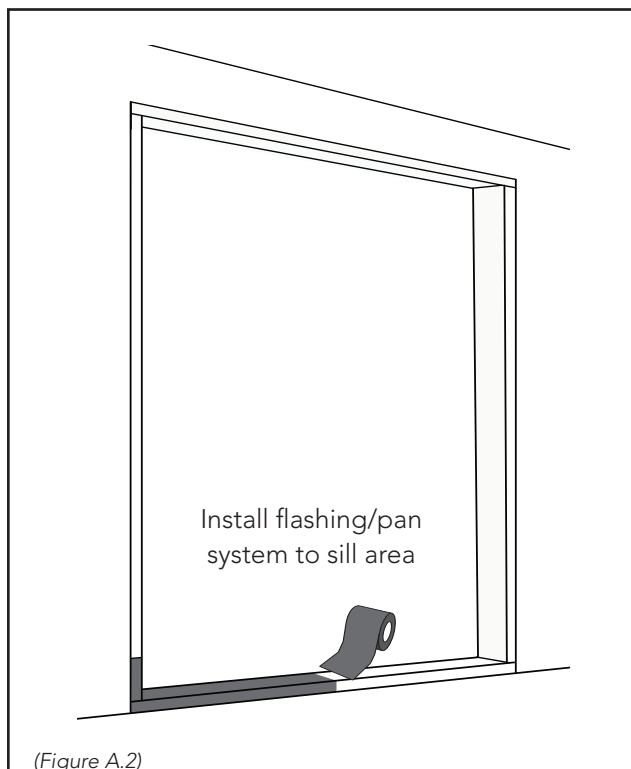
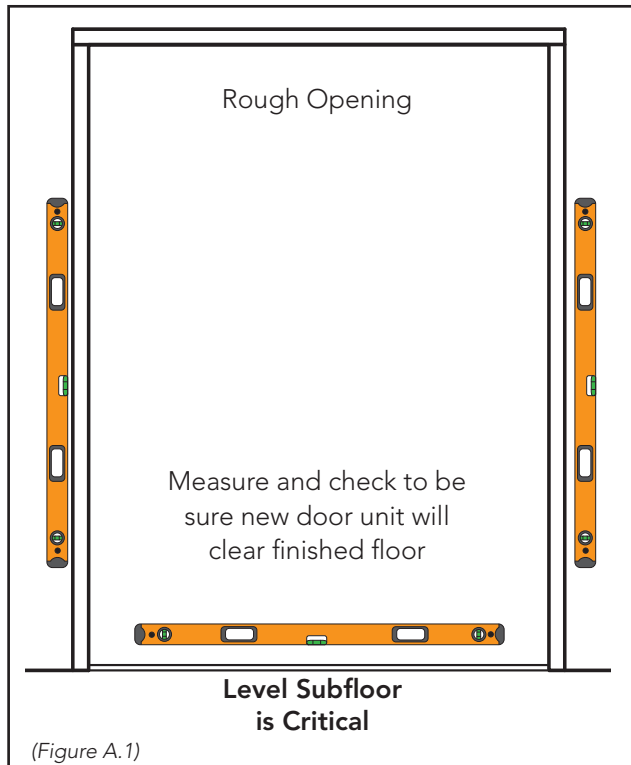

1

Opening preparation for replacement applications, remove existing door slab and jamb to expose rough opening.

NOTE: The rough opening will be from jack stud to jack stud, and sub-floor to underside of header. (Figure A.1)

2

Clean rough opening of all dirt, debris, and obstructions.

3

Check for level subfloor. Measure and check to be sure new door unit will clear carpet, hardwood, rug, etc. Subfloor may need to be built up for clearance.

4

Check to see if opposing walls are on the same plane. If not, new door unit will need to be adjusted to plane during installation.

5

For units ordered with aluminum cladding, remove all cladding from the brickmold.



IMPORTANT! Remove shipping slats from bottom of threshold before dry fit.

6

Dry fit unit to confirm opening clearances, plane of door, and support of exterior edge of threshold.

7

Remove door unit from opening and make any necessary modifications to the opening.

8

Install flashing/pan system to sill area in accordance with local building codes and best practices. Replace drip cap if necessary. (Figure A.2)

9

If exterior edge of threshold requires support, add material to the exterior surface of the structure at the sill.

A. PREPARATION (CONTINUED)

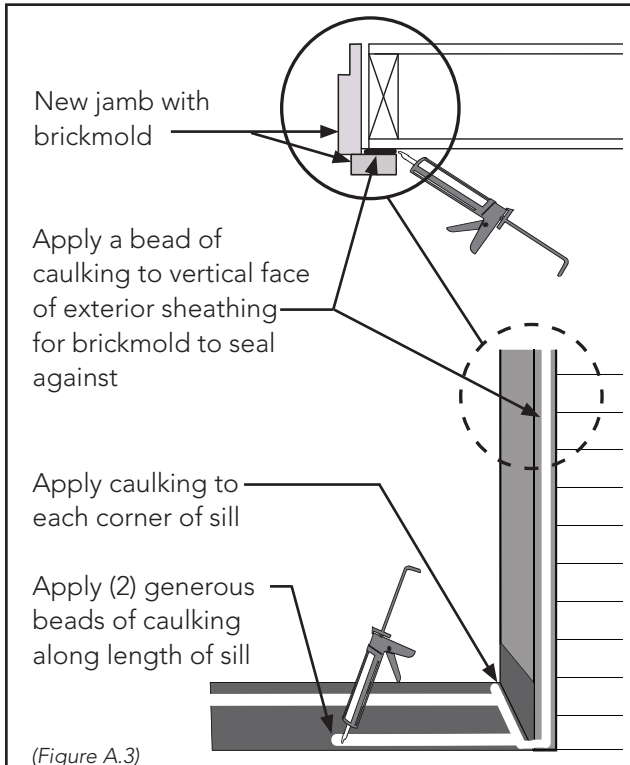

10

Apply (2) generous beads of premium caulking compound in a STRAIGHT LINE, on top of flashing and along entire length of rough opening sill. Place first bead of caulking to the exterior leading edge of sill. The second bead of caulking should be placed towards the interior, under the composite riser of the threshold. Apply caulking in each corner of sill. (Figure A.3)

11

Apply a bead of caulking to each vertical and header face of exterior sheathing to seal brickmold. For a complete seal, apply bead of caulk from sill to exterior sheathing, as shown. (Figure A.3)

B. INSTALL NEW DOOR UNIT

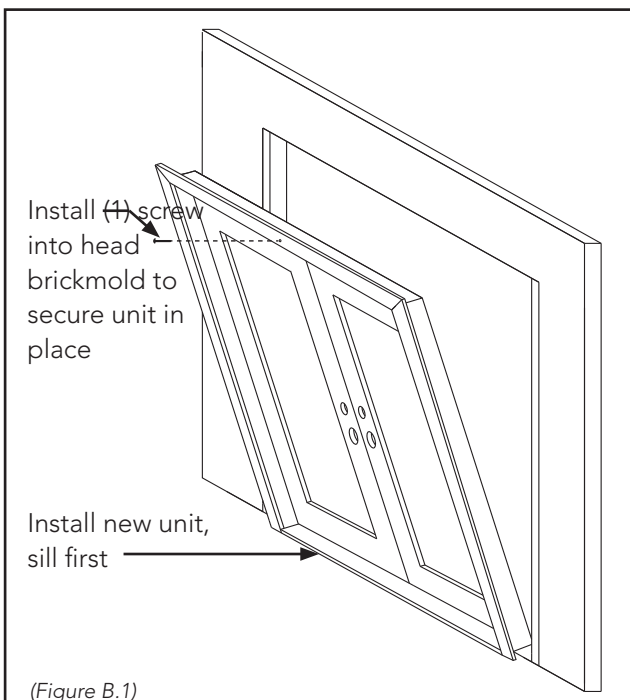

1

Set new door unit into opening sill first, as shown in illustration. (Figure B.1)

2

From the interior side, center door on existing base board or paint lines.



IMPORTANT! Ensure active and non-active door slabs are equal in center height.

3

If new unit was ordered with brickmold attached, fasten the head brickmold to exterior sheathing with (1) decking screw. (Figure B.1)

B. INSTALL NEW DOOR UNIT (CONTINUED)

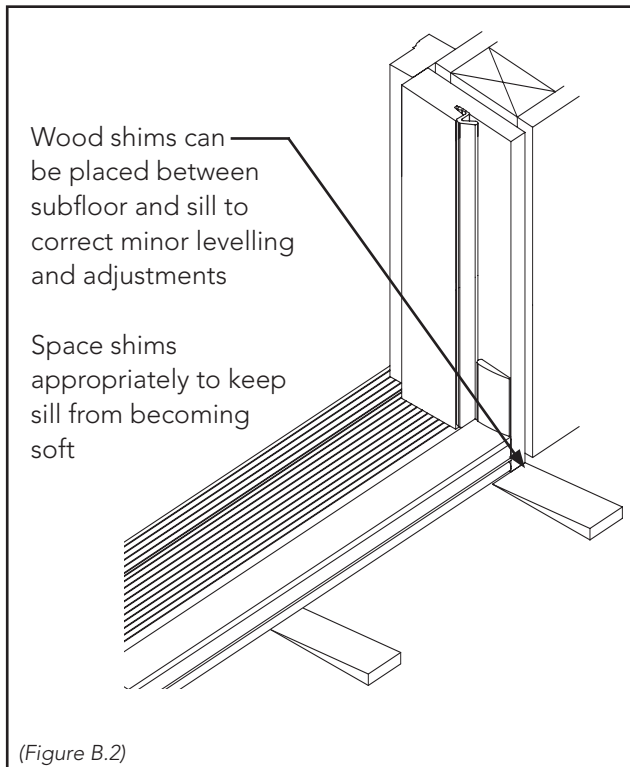

4

Check for level sill. Place wood shims between subfloor and jamb to correct minor leveling and margin adjustments, $\frac{1}{8}$ " or less. (Figure B.2)



IMPORTANT! A level sill is critical. If sill is not flat, straight and level, it must be shimmed for proper operation of door. Be careful to NOT over shim. Improper shimming may change the margins and jeopardizing operational performance of door.

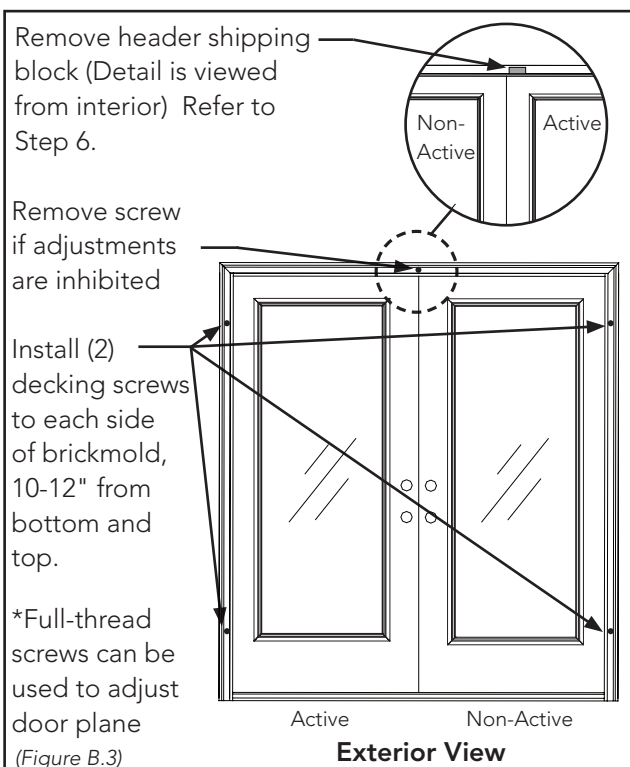

5

Install decking screws on each vertical side of brickmold, 10"-12" from the bottom and 10"-12" from the top. (Figure B.3)

NOTE: Full-thread screws can be used to adjust door plane. Refer to Troubleshooting Section.

6

From the interior, unlock the deadbolt and remove shipping block located at header of active door slab. (Figure B.3)

B. INSTALL NEW DOOR UNIT (CONTINUED)

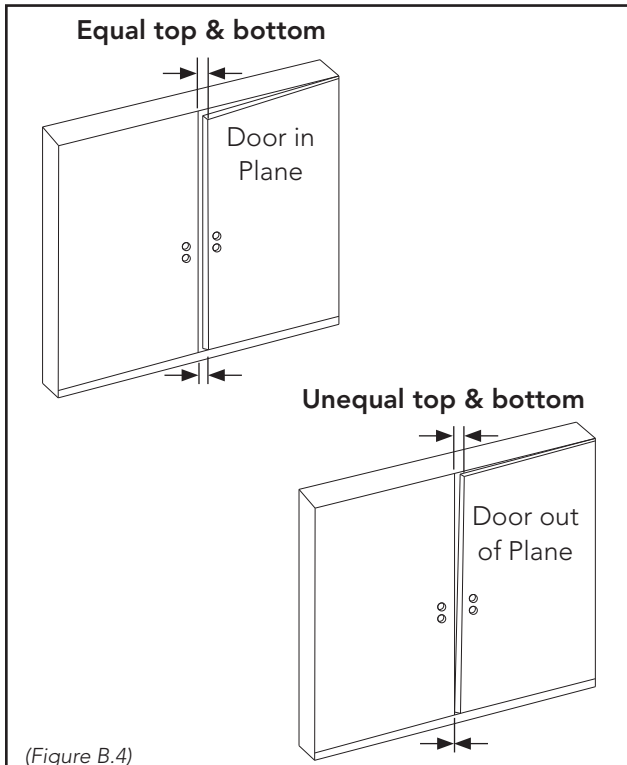

7

Inspect plane of door unit by comparing edge of door slab to edge of door slab. The edges should be parallel. If door is out of plane (the door slabs are not parallel to each other), refer to Troubleshooting Section and adjust accordingly. (Figure B.4)



IMPORTANT! Plane adjustment is critical for door operation and sealing performance. Plane should be continuously monitored throughout the installation. Confirm all other adjustments made to not compromise plane. Adjustments to plane after complete install may require removal and re-installation.

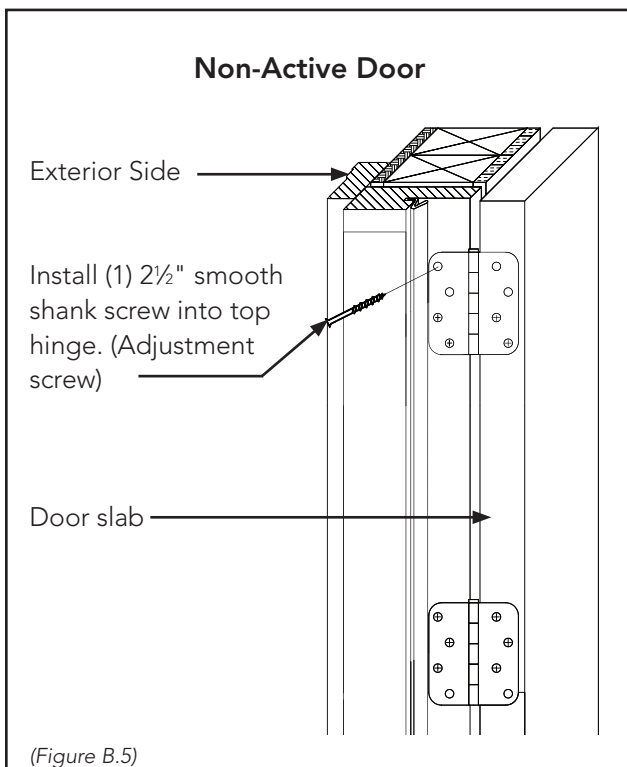

IMPORTANT! Pre-drill for all screws to be installed using a 1/8" drill bit.

8

Install (1) 2 1/2" smooth shank screw (not provided) into top hinge of non-active door slab to draw the top of the slab towards the jamb. Use this screw for adjustments. (Figure B.5)

B. INSTALL NEW DOOR UNIT (CONTINUED)

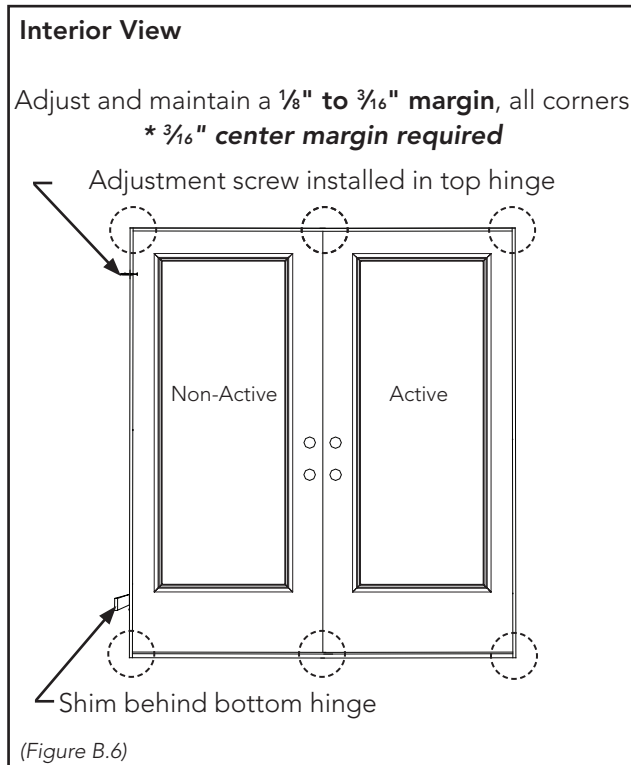

9 To counteract the weight of the door slab compressing against the bottom hinge and jamb, add shims behind the bottom hinge location of non-active side. Use the adjustment screw in top hinge and the shim behind bottom hinge to set a $\frac{1}{8}$ " - $\frac{3}{16}$ " margin between door slabs and jambs. With the completion of installation, all (4) corners and the center margin are to hold a $\frac{1}{8}$ " - $\frac{3}{16}$ " margin. **Note, the strike plates are surface mounted. This will require a $\frac{3}{16}$ " CENTER margin for proper clearance.** (Figure B.6)



IMPORTANT! Proper shimming application; stack wedge shaped shims contrasting and plane to plane.

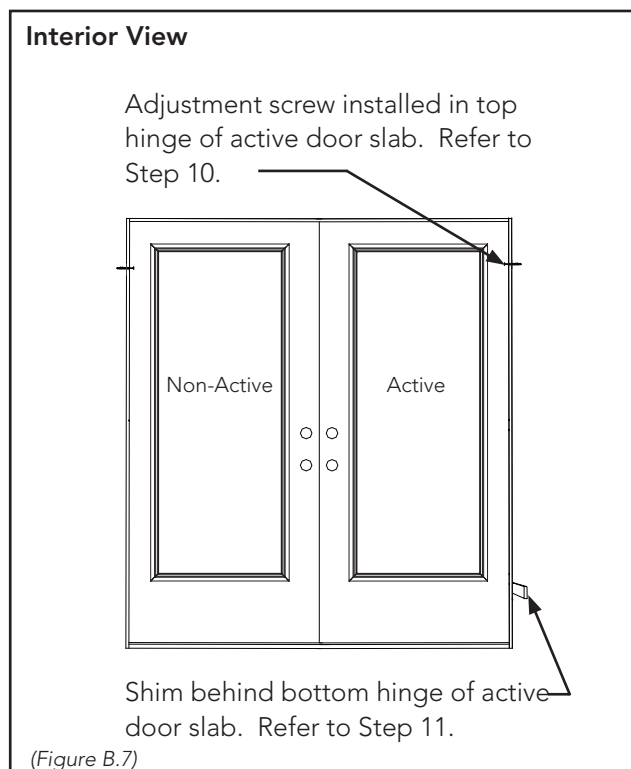

IMPORTANT! Constantly monitor center reveal between the door slabs during following adjustment process.

10 Install (1) $2\frac{1}{2}$ " smooth shank screw (not provided) into top hinge of active door slab to draw the top of the slab towards the jamb. Use this screw for adjustments. (Figure B.7)

11 Add shims behind the bottom hinge of active door slab. Use the adjustment screw in top hinge and the shim behind bottom hinge to set a $\frac{1}{8}$ " - $\frac{3}{16}$ " margin between door slab and jamb. (Figure B.7)

B. INSTALL NEW DOOR UNIT (CONTINUED)

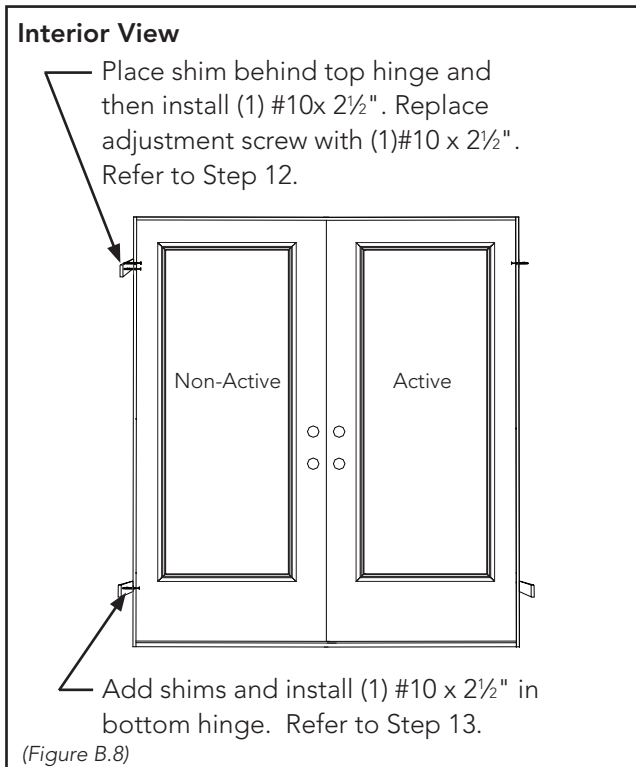

12

After margins are set, shim behind the top hinge of non-active slab until tight to the adjuster screw. Install (1) #10 x 2½" screw (provided) in the remaining hole location of hinge. Then replace the adjustment screw with (1) #10 x 2½" screw. (Figure B.8)

NOTE: The #10 x 2½" hinge screws will be included in the hardware box or stapled to the side of the jamb.

- For **3-HINGE DOORS**, (8) screws will be provided.
- For **4-HINGE DOORS**, (10) screws will be provided

13

Add shims and install (1) #10 x 2½" screw in the bottom hinge of the non-active door slab. Check corner margins. (Figure B.8)

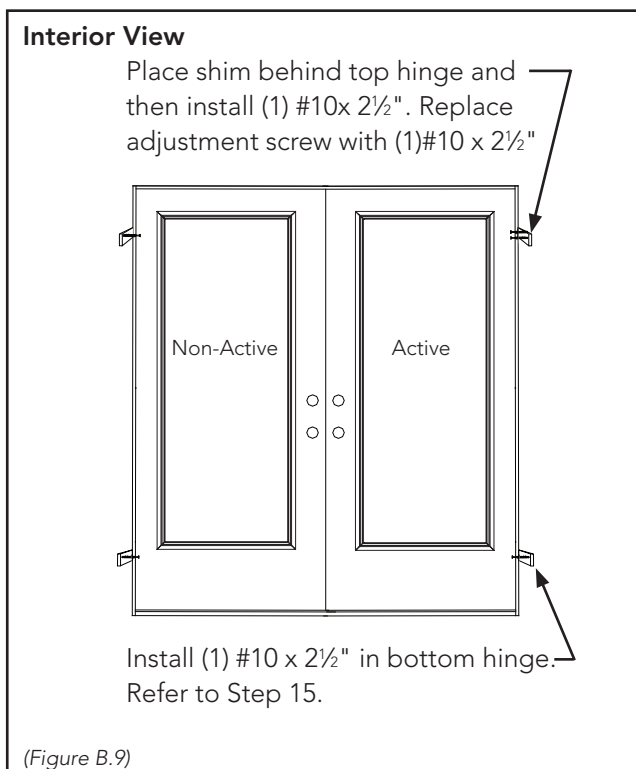

14

Shim behind the top hinge of active door slab until tight to the adjuster screw. Install (1) #10 x 2½" screw (provided) in the remaining hole location of hinge. Replace the adjustment screw with (1) #10 x 2½" screw. (Figure B.9)

15

Install (1) #10 x 2½" screw in the bottom hinge of active slab. Check corner margins. If margins have deviated, adjust shims accordingly. Refer to Troubleshooting Section. (Figure B.9)

B. INSTALL NEW DOOR UNIT (CONTINUED)

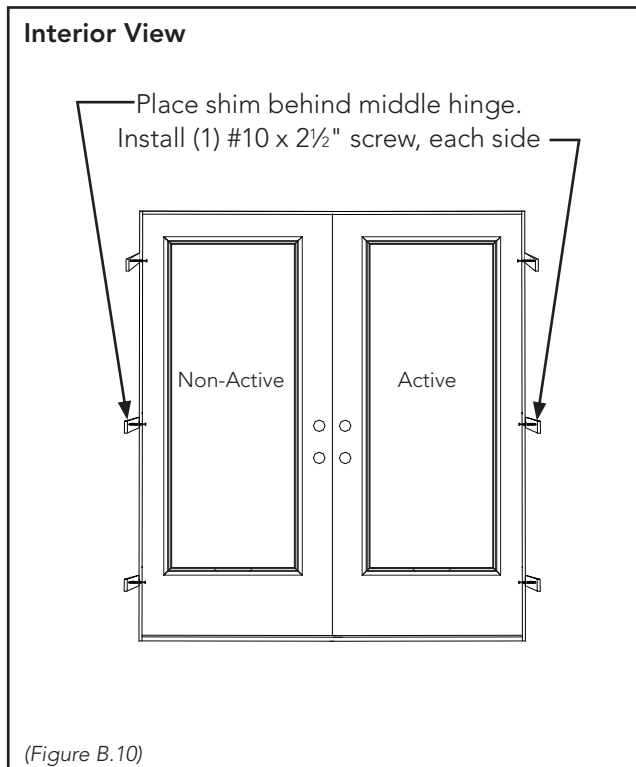

16

Shim behind middle hinge of active and non-active door slabs. Install (1) #10 x 2½" screw into open hole of each. For 4-HINGE DOORS, repeat for each middle hinge. (Figure B.10)

17

Shim above header strike plate (header strike plate is factory installed). Remove (2) #8 x ¾" Phillips flat head screws and replace with (2) #6 x 2½" Phillips flat head screws (included in the Astragal Component Pack). (Figure B.11)

NOTE: The **lower bolt receiver cup** found in the Astragal Component Pack is **NOT** needed. Please discard this component.

18

Check for proper operation and alignment of top bolt pin. Close active door and engage bolt pin. Pin to secure within center hole of header strike plate.

19

Shim at least (2) additional header locations, centered over each door slab as shown in illustration. Pull back weatherstripping, pre-drill and install a decking screw at the shim locations. (Figure B.11)

20

Final check on all margins. Adjust shims and screws as needed to achieve and maintain a ⅛" - ⅜" margin around the entire door. Shim and secure additional areas of the PermaTech™ jamb as needed to achieve and maintain required margins. Refer to Troubleshooting Section.

NOTE: The additional shims and fasteners may help to prevent possible movement of the composite material.

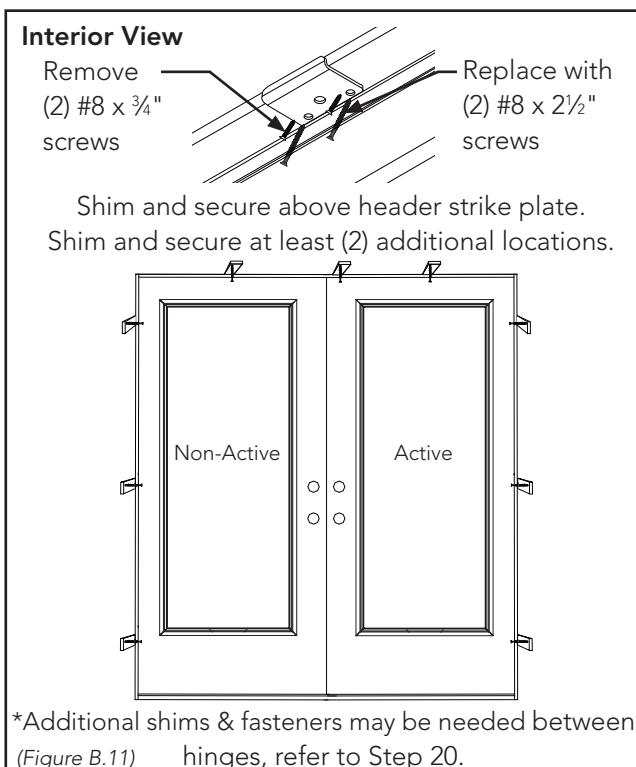

IMPORTANT! Be careful to **NOT** over shim. Improper shimming may change the margins and jeopardize the operational performance of door.

C. ADJUST HANDLESET AND DEADBOLT STRIKE PLATES

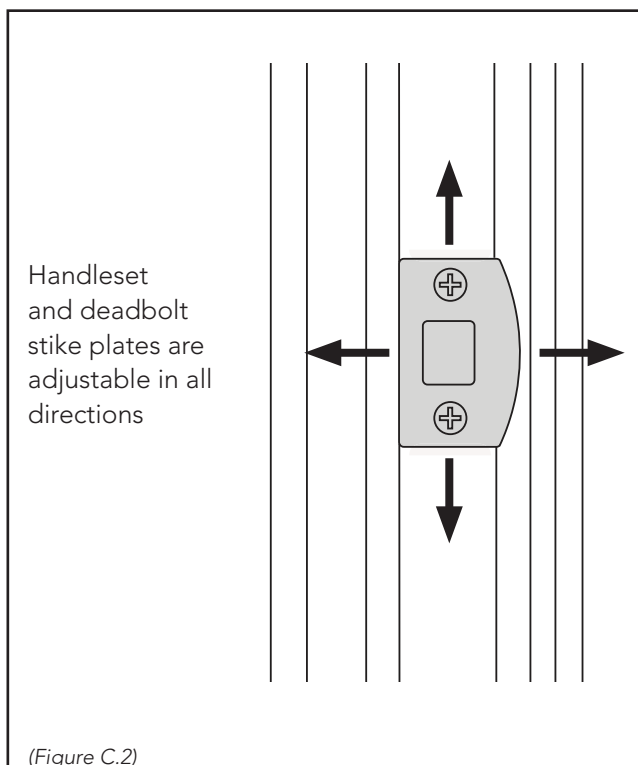
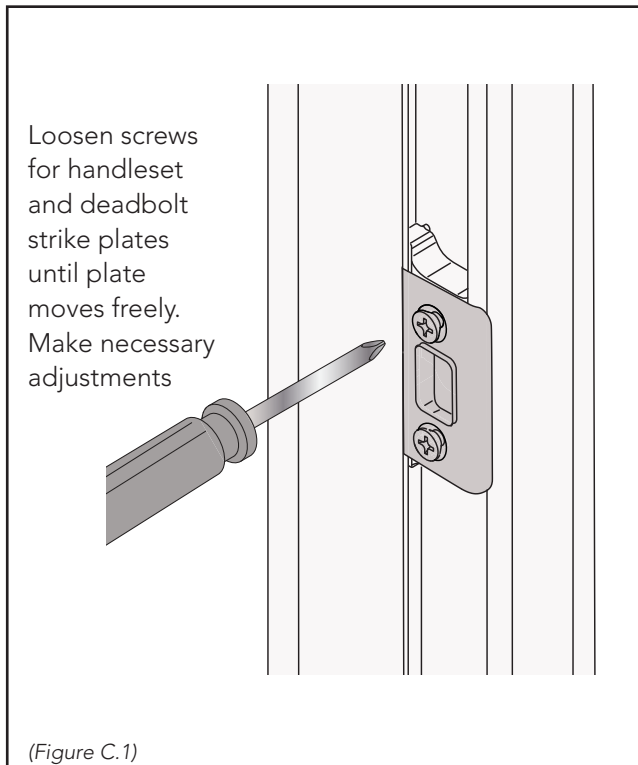

IMPORTANT! Handleset and deadbolt strike plates are factory installed. Each plate will adjust up and down as well as in and out.

1

Install handleset according manufacturer's instructions included in hardware box.

2

If handle set strike plate requires adjustment, loosen strike plate screws until plate moves freely. Move plate to desired location and re-tighten screws to a test location. Once final location is reached, tighten screws to set tips into the astragal body. (Figure C.1 & C.2)

NOTE: The endpoint of the strike screw must make contact with the inside of the astragal. This will set the screw to the astragal, preventing strike plate movement during operation.

3

If deadbolt strike plate requires adjustment, loosen strike plate screws until plate moves freely. Move plate to desired location and re-tighten screws to a test location. Once final location is reached, tighten screws to the strike retainers. (Figure C.2)

NOTE: Screws will not make contact with astragal body.

D. OUTSWING DOOR WITH SECURITY FLANGE (OPTION)

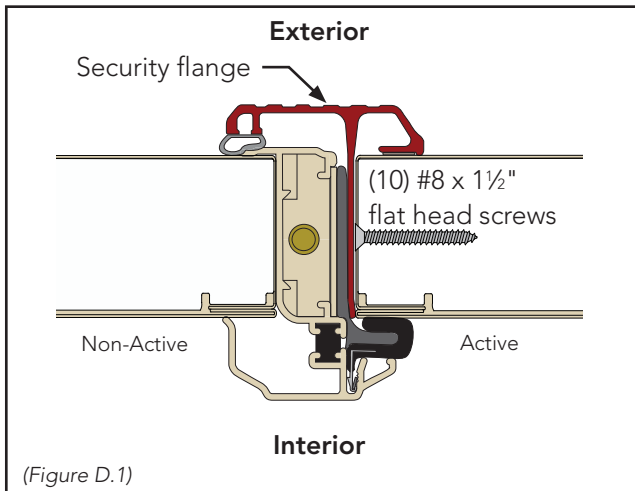

IMPORTANT! Security Flange is factory installed on all outswing doors. The security flange covers the gap between door slabs to minimize exterior exposure. Security flange will effect margin between doors.

1

Be sure security flange is tight against face of active door.

2

Basic installation is the same with the exception of contact point of door slab to the threshold.

E. FINAL ADJUSTMENTS AND SEAL

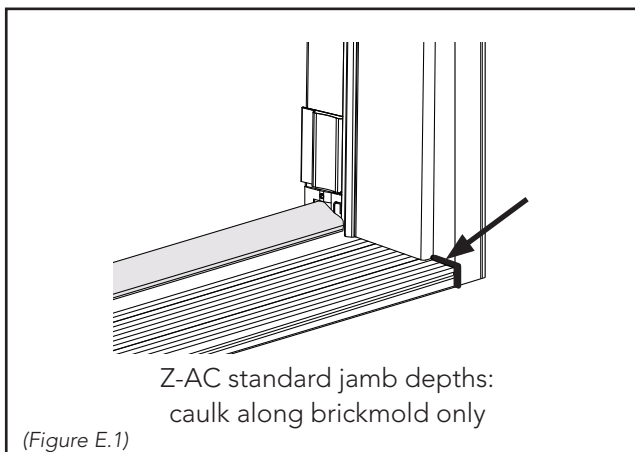

1

Add (3) installation decking screws to each exterior vertical brickmold piece and head piece to ensure brickmold is fully secured.

2

Apply caulk or construction adhesive to all brickmold. Re-install all aluminum brickmold cladding.

3

Caulk threshold.....

- **Z-AC™** thresholds with a 4 $\frac{1}{16}$ " or 6 $\frac{1}{16}$ " jamb depth, only need caulked at the brickmold and threshold intersection. If desired, caulk along entire joint where jamb meets the threshold. (Figure E.1)

- **Z-AC** threshold with custom jamb depth: caulk along entire joint of threshold where the jamb meets the threshold and along the brickmold joint. (Figure E.2)

- **ZAI** threshold: Carefully remove each corner seal pad. Check between door sweep and sill cap for even seal. If adjustments are needed, refer to Section G, page 12. After adjustments, caulk joint between sill cap and jamb, on the front and top edges of cap. Caulk along entire joint where jamb meets the threshold and along the brickmold joint. Reinstall each corner pad tight to cap. (Figure E.2)

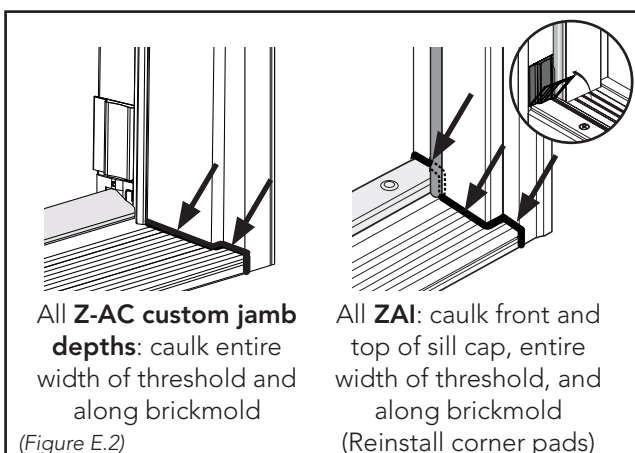

E. FINAL ADJUSTMENTS AND SEAL (CONTINUED)

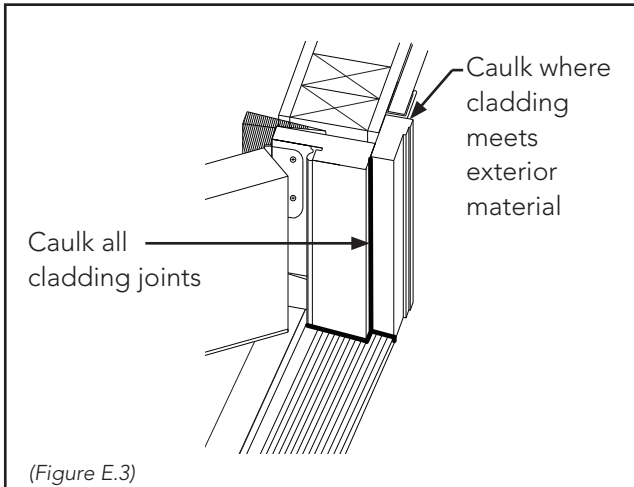

4

Caulk around ALL cladding joints. Be sure to apply caulking around perimeter where cladding meets exterior sheathing/material. (Figure E.3)

5

Insulate by using an AAMA approved ASTM C 1620 Low-Expanding Foam to fill cavities between frame and opening.



Over use of Low-Expanding Foam or use of any non Low-Expanding Foam may cause frame to bow, jeopardizing operational performance of door.

F. THRESHOLD: Z-AC™ (AUTO-ADJUSTING) THRESHOLD ONLY

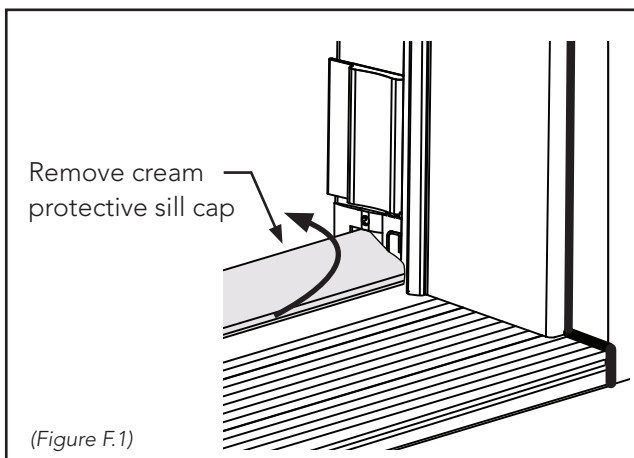

1

Remove the cream colored protective sill cap cover. For inswing door units, grasp cover from the exterior side, lift and pull. The cream cover may break, this is typical. (Figure F.1)

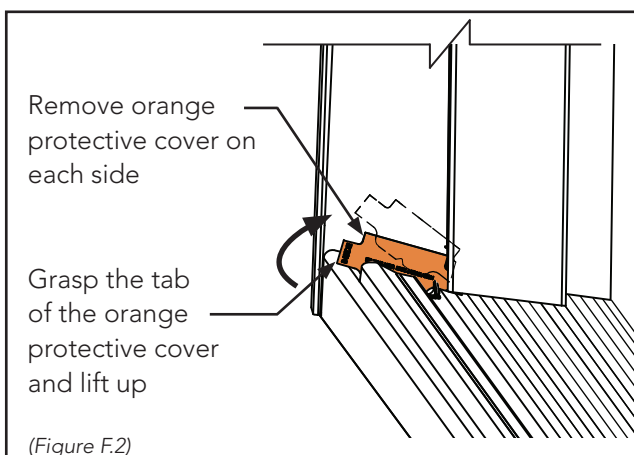

2

Remove the orange protective covers located at each jamb. Grasp the tab of the orange protective cover, marked 'Pull-Up'. Lift up and away from the sill base (pliers may be required). (Figure F.2)

NOTE: A small portion of the gasket, at the outside edge **ONLY**, will be removed with the protective cover, this is typical.

DO NOT remove any portion of foam gasket in removal of orange tab.

For ZAI threshold instructions, refer to section G, page 12

G. THRESHOLD: ZAI (ADJUSTABLE) THRESHOLD ONLY

The ZAI (Adjustable) threshold allows for adjustment of the sill height, thus providing a consistent and even seal. To adjust sill cap height, follow one of the two methods shown below:

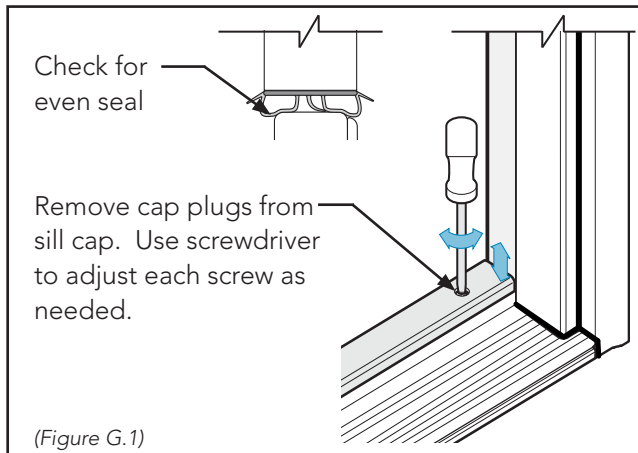

OR

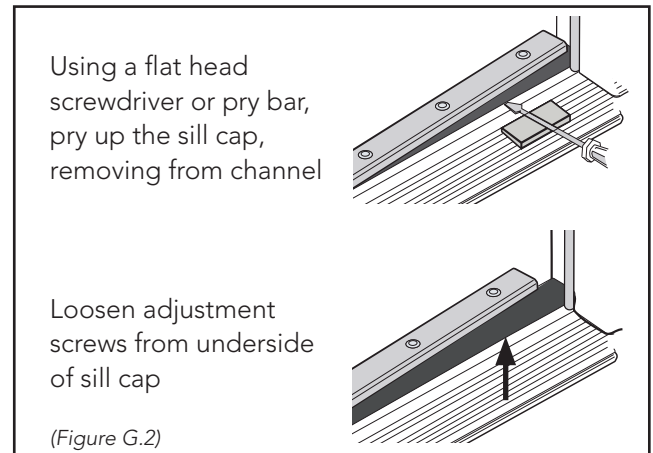

REMOVE CAP PLUGS:

- 1 Place tape around the cap plug to protect the finish. Use a flat blade to pry the cap plugs away from cap.
- 2 Use a screwdriver to adjust each screw as needed to achieve necessary height. (Figure G.1)
- 3 Open and close door to check adjustments.
- 4 Check for an even seal along full length of door sweep. Repeat process until proper seal is achieved. (Figure G.1)
- 5 Re-install the cap plugs. Use a rubber mallet if needed to secure plugs in place. If cap plugs are damaged during adjustment, replace with new plugs.

REMOVE SILL CAP:

- 1 Place a small piece of wood blocking on sill deck to prevent damage. At one end of the sill, use a flat head screwdriver or pry bar to pry the cap upward and away from the sill channel. Continue to work along the full length of threshold until fully removed from channel. (Figure G.2)
- 2 Access adjustment screws from the underside of the sill cap. Using a screwdriver, adjust screws as needed to achieve necessary height. (Figure G.2)
- 3 Re-install sill cap by snapping into channel. If needed, use a rubber mallet to tap into place. Leg of the sill cap should touch the threshold deck when properly seated.
- 4 Open and close door to check adjustments.
- 5 Check for an even seal along full length of door sweep. Repeat above steps until proper seal is achieved.

H. PAINTING PERMATECH™ COMPOSITE FRAME (OPTIONAL)

IMPORTANT NOTES BEFORE YOU BEGIN



With use of paints, mineral spirits, or other hazardous materials, always read and follow the manufacturer's instructions. ProVia, Inc. does not make any claims or representation as to proper use of paint products from other manufacturers and does not warranty any product that was painted outside of its factory.



With use of paints or solvents:

- Always make sure your working area is properly ventilated.
- Keep paints and solvents away from heat and flame as these materials can be combustible.
- Paints or solvents may cause skin and eye irritation. Avoid contact with skin and eyes.
- Keep out of reach of children.



Recommendation for water-based application: Acrylic-based primer with acrylic latex-based exterior grade paint.

Recommendation of brand of paint for PermaTech Composite Frame: Sherwin-Williams PrepRite® Bonding Primer with compatible acrylic paint for optimal paint adhesion.

Recommendation for paint selection: Select paint consisting of a LRV of 57 or higher. Please check paint or with manufacturer of the paint to determine the LRV value.

INSTRUCTION FOR PAINTING

1

Remove door slab with hinges from frame. Carefully lay frame horizontally on saw horses or table. Mask off areas not to be painted.

2

Use a Scotch Brite Pad or 320-400 grit sandpaper to lightly scuff the surface.

3

Use a lint-free cloth to gently clean frame with Acetone, removing all dust and residue from surface. Allow Acetone to fully dry.

NOTE: Wear solvent resistant gloves to clean surface.



DO NOT USE hydro-carbon based solvents to clean the surface. The use of such solvents could leave a residue on frame.

4

Use a 4" paint brush to apply primer to the PermaTech frame. Follow the manufacturer's instructions for drying time before applying topcoat. Be sure primer is completely dry before applying the topcoat.

5

Use a 4" paint brush to apply the exterior grade paint to the PermaTech frame. If applying a second coat, follow the manufacturer's instructions for drying time between coats. The topcoat must be completely dry before proceeding to the entry door installation.



TROUBLESHOOTING & TIPS

Problem	Cause	SOLUTION
Center margin is smaller at top than bottom	Over/under shimmed.	Adjust shims behind top and bottom hinges. Increase shims behind bottom hinge and decrease shims behind top hinge.
Center margin is larger at top than bottom	Over/under shimmed.	Adjust shims behind top and bottom hinges. Decrease shims behind bottom hinge and increase shims behind top hinge.
Center margin is wide.	Under shimmed.	Increase shims behind non-active and active door slabs.
Header margin is smaller above center astragal	Over shimmed at strike plate.	Decrease shims above header strike plate.
Header margin is larger above center astragal	Under shimmed at strike plate.	Increase shims above header strike plate.
Top of door slabs are uneven at center margin - active door is above inactive door	Over shimmed on active door side.	Decrease shims behind active door bottom hinge.
Top of door slabs are uneven at center margin - active door is below inactive door	Under shimmed on active door side.	Increase shims behind active door bottom hinge.
Tapered margin above top hinge. Margin is larger at the hinge.	Under shimmed at middle and top hinge.	Increase shims behind top and/or middle hinge.
Tapered margin above top hinge. Margin is smaller at the hinge.	Over shimmed at middle or top hinge.	Decrease shims behind top and/or middle hinge.
Tapered margin below bottom hinge. Margin is larger at the hinge.	Under shimmed at middle and bottom hinge.	Increase shims behind bottom and/or middle hinge.
Tapered margin below bottom hinge. Margin is smaller at the hinge.	Over shimmed at middle or bottom hinge.	Decrease shims behind bottom and/or middle hinge.
Top of active door slab protrudes inward, past jamb header and away from astragal weather strip.	Door out of plane.	One or a combination of the following: 1. Shift bottom of inactive hinge-side door jamb toward the exterior. 2. Shift the top of active hinge-side door jamb toward the exterior.

Troubleshooting & Tips continues on next page.



TROUBLESHOOTING & TIPS

Problem	Cause	SOLUTION
Bottom of active door slab protrudes inward, past threshold and away from astragal weather strip.	Door out of plane.	One or a combination of the following: 1. Shift top of inactive hinge-side door jamb toward the exterior. 2. Shift bottom of active hinge-side door jamb toward the exterior. <i>*Tip: If ordered with brickmold attached, using full-thread screws will allow the frame to be 'held' out from exterior sheathing in order to adjust plane.</i>
Interference of Z-AC cap with door slab.	Sill cap may not be fully seated.	Snap front leg of sill cap into place. Leg of the sill cap should touch the threshold deck when properly seated. If needed, use a rubber mallet to tap into place.

REMINDER to INSTALLERS:

Demonstrate function of double (French) door astragal to Homeowner. Be sure top and bottom astragal pins are correctly seated in designated locations to ensure proper function of unit.

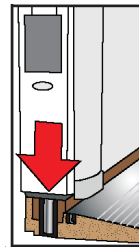
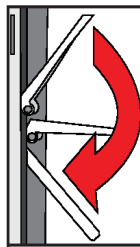

****Please call Customer Service for additional installation inquiries at 1-800-669-4711.***

****For additional information and helpful videos, visit our Homepage for Installers by TAPPING or SCANNING the QR code shown.***

